

E SERIES 2-POST LIFTS

Challenger's E Series lifts provide symmetric lifting capability with adjustable height to accommodate higher profile vehicles. The E12 model features a pulley-less jacketed single-point lock release system designed to last. All necessary adapters are included. Available in red or blue. ALI/ETL certified.



Stack adapter set and single screw footpad with engineered frame engagement included



E12 | 12,000 LB. CAPACITY

» 2-post symmetric lift



E15 | 15,000 LB. CAPACITY

» 2-post heavy-duty symmetric lift

CL Challenger Lifts

LOUISVILLE, KENTUCKY

SPECIFICATIONS

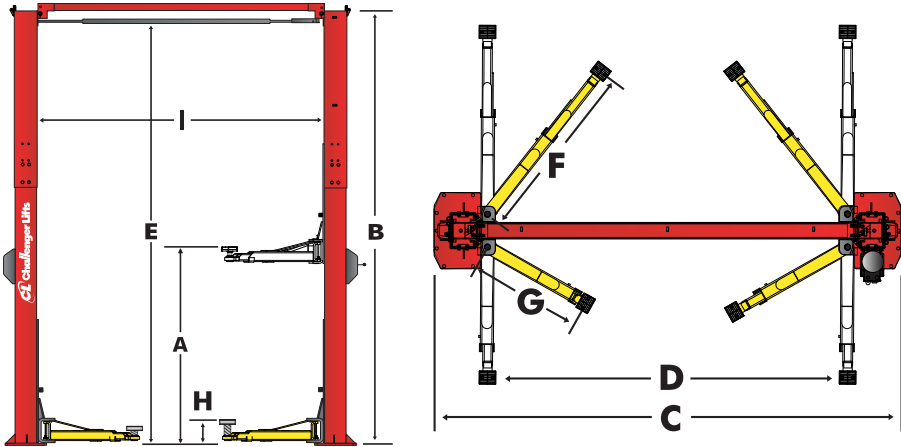

Model Number	E12	E15
Lifting Capacity	12,000 lbs. (5,443 kg)	15,000 lbs. (6,804 kg)
Arms	2-stage front/2-stage rear	2-stage front/2-stage rear
Lifting Configuration	Symmetric	Symmetric
A Rise Height ¹	77.75" (198 cm)	77.75" (198 cm)
B Overall Height	166"/175" (422 cm / 445 cm)	174"/198" (442 cm / 503 cm)
C Overall Width	139.75" (355 cm)	147.125" (374 cm)
D Drive-Thru Clearance	103" (262 cm)	109.375" (278 cm)
E Floor to Overhead Switch	159.5"/168.5" (405 cm / 428 cm)	166"/190" (422 cm / 487 cm)
F Maximum Arm Reach	54.5" (139 cm)	55" (140 cm)
G Minimum Arm Reach	35.75" (910 mm)	36.5" (927 mm)
H Screw Pad Height (Min. - Max.)	5.25"-6.75" (133 mm / 171 mm)	5.25"-6.75" (133 mm / 171 mm)
I Inside Columns	115" (292 cm)	122.25" (311 cm)
Ceiling Height Req.	167"/176" (424 cm / 447 cm)	175"/199" (445 cm / 506 cm)
Std. Motor/Voltage ²	2HP, 208v - 230v	2HP, 208v - 230v
Speed of Rise	61 s	75 s
ALI/ETL Certified	√	√
2' (61 cm) Height Extension Available	√	Included
Colors Available		

¹ Rise height is measured with high extension. ² Optional 3-phase electrical also available, please specify at time of order.

For more information, contact your Authorized Challenger Lifts Distributor:



2212 Camplain Rd., Hillsborough, NJ 08844

Call for Sales, Service, & Installation

www.fclift.com **908.526.1500**

800-648-5438 | 502-625-0700 | Fax: 502-625-0711 | Email: sales@challengelifts.com
2311 South Park Road | Louisville, KY 40219



FEATURES & BENEFITS

- » ALI certified
- » 12,000/15,000 lb. lift capacity
- » Heavy-duty 2-stage arms enable a wide range of symmetric lifting
- » Single point mechanical lock release allows technician to disengage both columns simultaneously
- » Heavy-duty polyurethane screw pads accommodate a wide range of recommended lifting points
- » Adjustable column height accommodates higher profile vehicles and provides maximum headroom to work underneath vehicles
- » Padded overhead shut off system prevents vehicle damage
- » Powder coat finish provides long-lasting durability
- » Plated arm restraints and arm pins inhibit rust and provide long-lasting durability
- » Standard dual integrated rubber door guards help protect vehicle panels from inadvertent damage
- » Jacketed pulley-less single-point mechanical lock release system that was once exclusive to our CL Series (E15 only)
- » Adjustable footpads, stack adapters, and organizer rack come standard



OPTIONAL ACCESSORIES

- » 2' column height extensions available for E12 model to accommodate higher profile vehicles
- » Air/electric work station