



2212 Camplain Rd., Hillsborough, NJ 08844

Call for Sales, Service, & Installation

www.fclift.com 908.526.1500



DOUBLE SCISSOR FLY 35

**AUTOMOTIVE AND LIGHT TRUCK GENERAL SERVICE
DESIGNED AND BUILT IN ITALY, AND USED BY THE WORLD'S
PREMIUM CAR MANUFACTURERS**

DOUBLE SCISSOR FLY 35

FULL-RISE PAD STYLE

7,700 LB./3.5T CAPACITY

**COMPACT DESIGN WITH OVERALL WIDTH OF
80"/2030MM RAISED HEIGHT OF 74.4"/1890MM**



FEATURES



▲
Volumetric Control



▲
Extended Ramps for low clearance vehicles and Hot-Dip Galvanization as optional accessories



▲
Flush or Surface Mounted

DOUBLE SCISSOR

7,700 LB. / 3.5T CAPACITY

AT OMER USA, OUR GOAL IS TO BUILD LIFTS THAT LAST LONGER, PERFORM BETTER, AND COST LESS TO OPERATE.

SPECIFICATIONS	
Capacity	7,700 lbs. / 3.5T
Overall Length - Surface Mount	83.3" / 2115mm
Overall Length - Flush Mount	83.3" / 2115mm
Overall Width	80" / 2030mm
Width Between Runways	31.5" / 800mm - Adjustable
Deck Width	24.2" / 615mm
Lowered Height	4.5" / 115mm
Raised Height	74.4" / 1890mm
Lifting Time	55 Secs. Raised / 30 Secs. Lowered
Power Requirements	230 Volts - 60 Hz - 1 PH - 23amp
Shipping Weight	1,870 lbs / 850kg
Part Number	OMRFLY35UL

FEATURES

- Built to higher standard of quality; made in Italy by O.ME.R S.p.A., a world leader in Lift Manufacturing for over 40 years in an ISO 9001 facility.
- No "post" design - Incorporating a smaller footprint than traditional 2-post lifts which maximizes efficiency and productivity of the shop floor.
- Electro-hydraulic double scissor lift, frame contact, low profile with oversized platforms, able to lift most types of vehicle.
- OMER's FLY incorporates a single cylinder on each platform with pneumatically activated safety lock.
- Ultra low-profile max height 4.5" for an easy and comfortable installation without requiring pits for the inground version.
- Lift without electronic sensors, increasing reliability.
- Multiple safeties integrated into design, involving velocity fuse on each cylinder, max pressure valve, acoustic warning for the final descent, low voltage control circuit (24v) and "dead-man" controls.
- Hydraulic and mechanical synchronization system - simple and reliable.
- ALI Certified
- Hot-Dipped Galvanization of the whole structure as an option, offering extra protection from corrosion due to water or salt exposure, extending the life of the equipment.

OPTIONAL ACCESSORIES

- Hot Dipped Galvanized
- Optional 3-phase Power Supply
- Low Approach Ramps
- Traverse Kit

EQUIPMENT FOOTPRINT

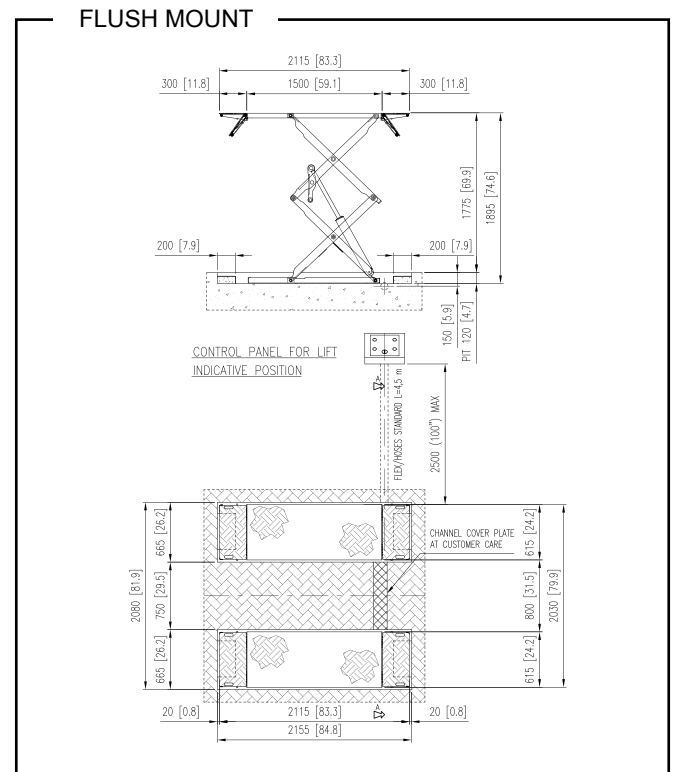
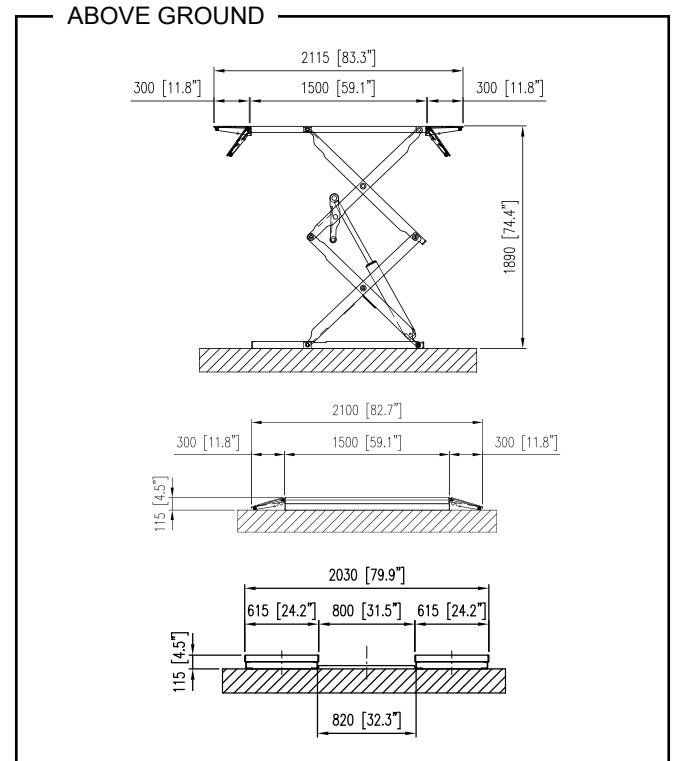

CONTACT US NOW

WWW.OMERINC.COM

CALL +1(470) 275-5919



2212 Complain Rd., Hillsborough, NJ 08844
Call for Sales, Service, & Installation
www.fcift.com 908.526.1500



OMER®