

9,000 lbs. Capacity

(4,500 lbs. per axle)

Minimum wheelbase 115" at rated capacity

INSTALLATION / OWNERS MANUAL

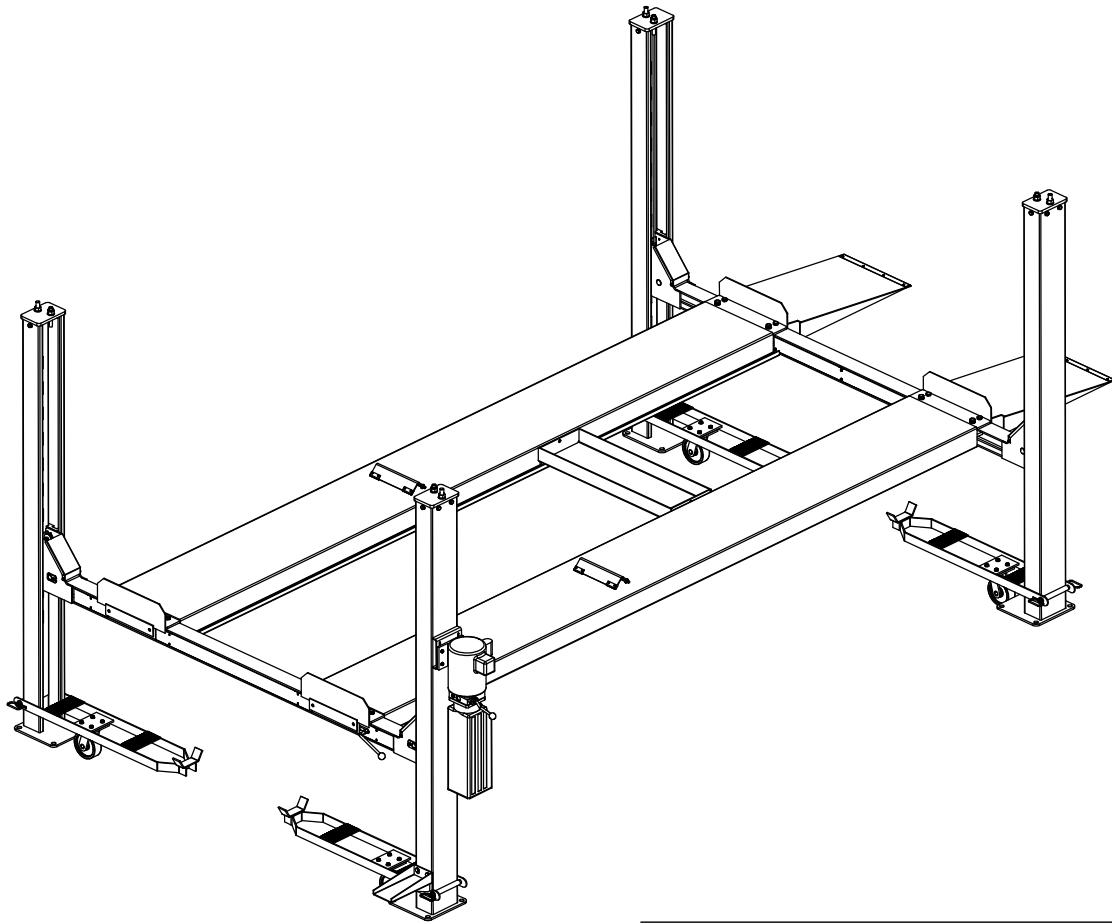

⚠ IMPORTANT Reference ANSI/ALI ALIS, Safety Requirements for Installation and Service of Automotive Lifts before installing lift.

Read this manual thoroughly before installing, operating, or maintaining this lift. When done with installation be sure to return documents to package and give all materials to lift owner/operator. When installation is complete be sure to run lift up and down a few cycles with and without "typical" vehicle loaded on lift.

TABLE OF CONTENTS

- IMPORTANT INFORMATION pg 2
- TOOLS REQUIRED pg 4
- LIFT SPECIFICATIONS pg 4
- Floor Plan pg 5
- INSTALLATION INSTRUCTIONS pg 6
- CASTER KIT ASSEMBLY / INSTALLATION pg 8
- FOUNDATION & ANCHORING REQUIREMENTS..... pg 9
- OWNER / EMPLOYER RESPONSIBILITY pg 13
- LOCKOUT / TAGOUT pg 13
- SAFETY PROCEDURES pg 15

- OPERATION INSTRUCTIONS..... pg 13
- PREVENTIVE MAINTENANCE SCHEDULE pg 15
- TROUBLESHOOTING pg 17
- CABLE INSPECTION GUIDE pg 19
- ILLUSTRATED PARTS LIST..... pg 26

IMPORTANT INFORMATION

Four Post Lifts

1. Always inspect the lift for damage and make note of any damage on the bill of lading.
2. In case of freight damage, call the truck line immediately and report the damage as a freight claim.
3. Make sure you have extra help or heavy duty lifting equipment when unloading and assembling the lift.
4. Please read the safety procedures and operating instructions in this manual before operating lift.
Keep this manual near lift at all times. Make sure all operators read this manual.
5. NOTE: Are you installing in a level location? (Lift must be anchored in place if slope is greater than 1/8" per foot.)
6. Make sure you have enough room to install the lock rods. You will need at least 9' of clearance from the opposite end of the power unit end of the lift and 6' at the power unit end. (See floor plan on page
7. The power unit may be installed on the driver's front or the passenger rear corner.
8. Never raise a car until you have double checked all bolts, nuts and hose fittings.
9. Always lock the lift before going under the vehicle or storing another vehicle underneath lift.
Never allow anyone to go under the lift when raising or lowering.

This is a vehicle lift installation/operation manual and no attempt is made or implied herein to instruct the user in lifting methods particular to an individual application. Rather, the contents of this manual are intended as a basis for operation and maintenance of the unit as it stands alone or as it is intended and anticipated to be used in conjunction with other equipment.

Proper application of the equipment described herein is limited to the parameters detailed in the specifications and the uses set forth in the descriptive passages. Any other proposed application of this equipment should be documented and submitted in writing to the factory for examination. The user assumes full responsibility for any equipment damage, personal injury, or alteration of the equipment described in this manual or any subsequent damages.

LIFT SPECIFICATIONS & FLOOR PLAN	
Capacity	9,000 lbs
Lifting Height	84" (7'0")
Ceiling Height to be height of highest vehicle to be raised plus	84" (7' 0")
Overall Length w/ Ramps	223-1/2" (18' 7-1/2")
Overall Length w/ no Ramps	192-1/2" (16' 1/2")
Overall Width	121" (10'1")
Approach Ramp Length	31" (2'7")
Runway Width	21-1/2" (1' 9-1/2")
Runway Length	188" (15'8")
Runway Height	4-3/4"
Height of Columns	97" (8'1")
Clearance between Columns	109.5" (9'1-1/2")
Clearance between Runways	39"
Outside Runway to Outside Runway	79" (6' 7")
Clearance Under Runway	81" (6' 9")
Motor specs	110VAC, 1HP
Shipping Weight	2,350 LBS

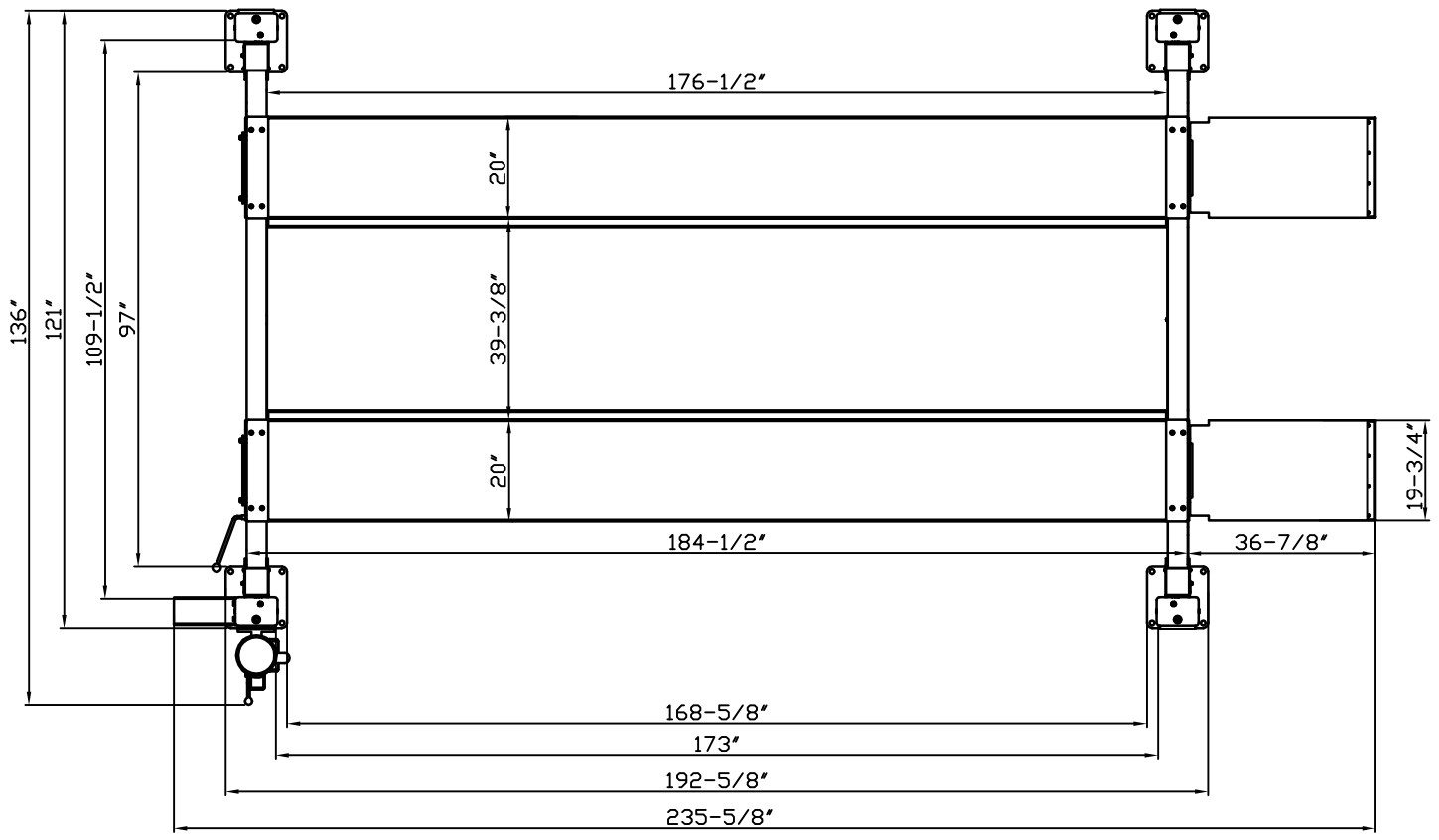
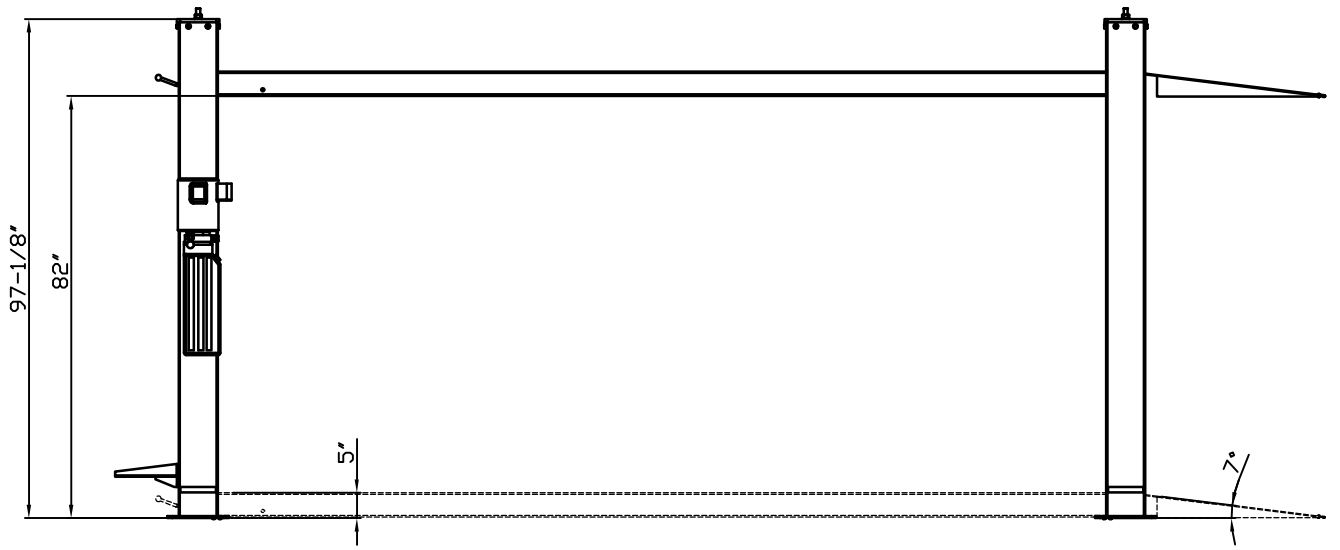

TOOLS REQUIRED

- Set of metric wrenches and/or sockets
- Adjustable wrench
- Locking pliers
- 25' Tape measure
- Step Ladder
- *3 Gallons of Hydraulic Oil

*Recommended Oil: ISO 32 Light Hydraulic Oil

INSTALLATION INSTRUCTIONS

1. Remove plastic wrap from top runway and remove all hardware. This includes the Power Unit, Drip Trays, Tool Box and / or any Jacks. Note: You should find this manual either in the top of the runway or inside the Power Unit box.
2. While the Mainside Runway (Item # 5) Figures # 3 & 6 is upside down, find the end of the Hydraulic Hose that is already connected to the cylinder. Locate the hole in the side of the runway and install the 90 degree Fitting (Item # 76) securing to runway with Jam Nut. Also remove all of the plastic ties securing the cables. Extend the cable ends through the runway ends. Remove cylinder rod shipping block. Tighten hydraulic fittings.
3. Extend cylinder piston rod out by pushing or pulling on the Cable Lock Plate (A) (Item # 79) Figure # 3 on the end of the cylinder. Now unbolt the top runway taking the necessary safety precautions. Note: Using some type of a hoist is recommended, this runway will need to be flipped over so it is no longer upside down. Place this runway in your bay with the hydraulic fitting facing toward your previously chosen corner for the power unit.
4. Next unbolt all four columns from the shipping package and place the column with the power unit mounting bracket in the above chosen corner. Arrange the other three columns in the remaining corners.
5. Unpack the Crossbeams, Ramps, Safety Latch Linkage Rods and Lock Ladders from bottom Runway. Remove the Safety Latch Covers (Items # 45) Figure # 1. They will be reinstalled later. Arrange the Crossbeams so that the locking linkage is facing outward and the Short Connecting Rod (B) (Item # 87) Figure # 5 is closest to the power unit column. Also, remove Crossbeam Covers (Items # 24, 25 & 26) Figure # 7 if not already removed.
6. If you have means for securely lifting the Crossbeam, lower it into the tops of the columns. If you don't, then the columns will have to be placed horizontal, and the crossbeams installed in the columns. Then the entire end structure (two columns and crossbeam) will need to be stood up as one.
7. Unpack the Lock Ladders (Item # 38) Figure # 2 from the package and slide them into the precut slot on

the Rub Blocks (Item # 50) Figure #1 inside each column. After removing the top nut from the lock ladder you are ready to install the Top Caps A&B (Items # 44 & 94) Figures # 2 & 6 on the columns.

8. Be aware of the offset hole in column Top Caps. Arrange them so that the cable mounting holes are closest to the runways. Use provided bolts, nuts, washers, and lock washers to install Top Caps as shown in Figure # 2.
9. Secure Top Cap and Lock Ladder assemblies together with Washer and Nut (Items # 40 & 41) Figure # 2. Position the Crossbeams at the second lowest locking position on all columns.
10. Stand up and arrange the two end structures (Columns & Crossbeams) so that the outside of the Cross beam rail to the outside of the other Crossbeam rail measure's 184.5". Compare the measurements from the left and the right until they are diagonally within 1/2". The 1/2" variance will help in mounting the runways later.
11. Lift and position each Runway into place and secure with the provided Hex Bolts, Lock Washer, Flat Washer and Nut (Items # 34, 35, 36 & 37) as shown in Figure # 7. The lift will square itself as you further assemble it.
Note: Install the Offside Runway (Item # 4) opposite from the Mainside Runway (Item # 5) and Power unit Column as shown in Figure # 7.
12. Begin cable routing installation by removing the Cable Sheaves, Shafts and Spacers from all four corners of the Mainside Runway as shown in Figure # 4.
13. Route and mount the appropriate Cable(s) (Items # 48, 49, 50 & 51) to each Column Top Cap, while ensuring that the Plastic Cable Pulley (Item # 58) is between the Cable and the Lock Ladder as shown in Figures 1 & 8. This will allow the secondary slack cable lock to function properly. See Figure # 8 for Cable routing installation.
14. Reinstall the Cable Sheaves, Shafts, Spacers and hardware as shown in Figures # 4.
Note: Make sure all Cables are properly routed around Cable Sheaves.
15. Install all Lock Rods & Linkage components per the drawing on (Page 20) Figure #5. Also, install the Crossbeam Bracket (Item # 28) to middle / outside of each Crossbeam. Secure with the provided Hardware (Items # 29 & 30) Figure # 7.
16. Mount the Power Unit (Item # 7) to the Mainside Column with the attached mounting bracket using the Hardware (Items # 16, 17 & 103) provided as shown in Figure # 6. Once mounted, fill the Power Unit reservoir tank with hydraulic fluid. Now, install the 90 degree Hydraulic Fitting (Item #75) Figure # 3 to the high pressure port on the Power Unit. Connect the electrical power to the Power Unit see Figure A and Figure B.

CAUTION!! Never operate the motor on line voltage less than 208V. Motor damage may occur.

IMPORTANT!! Use separate circuit for each power unit. Protect each circuit with time delay fuse or circuit breaker. For single phase 208-230V, use 20 amp fuse. Three phase 208-240V, use 15 amp fuse. For three phase

400V and above, use 10 amp fuse. For 3Ø wiring see Fig. B. All wiring must comply with NEC and all local electrical codes.

Note: 60Hz. single phase motor CAN NOT be run on 50Hz. line without a physical change in the motor.

17. Install the "braded" Hydraulic Hose (Item # 74) to the Fitting on the side of the Mainside Runway and attach the other end to the 90 degree Fitting on the Power Unit as shown in Figure # 3.
18. Now raise the complete unit (Lift) and set at one of the bottom lock positions. Place level on crossbeam.

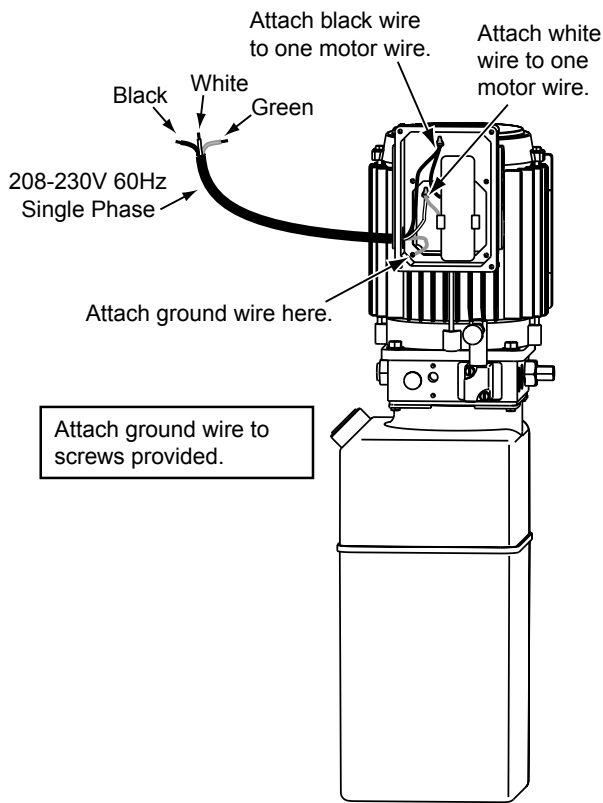

Single Phase Power Unit

MOTOR OPERATING DATA TABLE - SINGLE PHASE	
LINE VOLTAGE	RUNNING MOTOR VOLTAGE RANGE
208-230V 50Hz.	197-253V
208-230V 60Hz.	197-253V

Note: 60Hz. Single phase motor CAN NOT be run on 50Hz. line without a physical change in the motor.

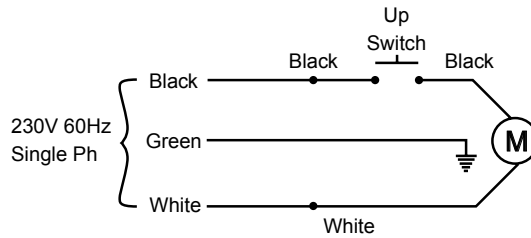

MOTOR OPERATING DATA TABLE - THREE PHASE	
LINE VOLTAGE	RUNNING MOTOR VOLTAGE RANGE
208-240V 50/60Hz.	197-253V
400V 50Hz.	360-440V
440-480V 50/60Hz.	396V-528V
575V 60Hz.	518V-632V

NOTES:

1. Unit not suitable for use in unusual conditions. Contact Rotary for moisture and dust environment duty unit.
2. Control Box must be field mounted to power unit.
3. Motor rotation is counter clockwise from top of motor.

FIGURE A

NOTE: Two Different Drum Switches were used please select one of the two options below.

NOTES:

1. Unit not suitable for use in unusual conditions. Contact Rotary for moisture and dust environment duty unit.
2. Control Box must be field mounted to power unit.
3. Motor rotation is counter clockwise from top of motor.

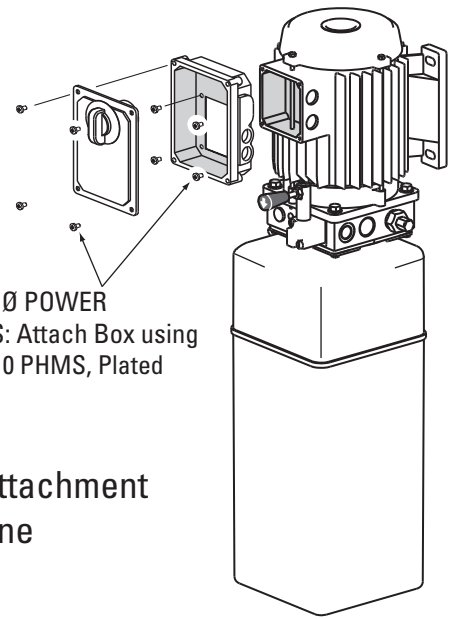
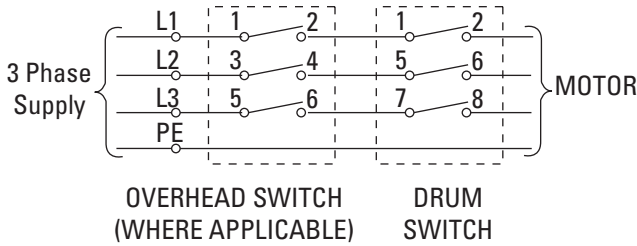

Capacitor Box Attachment Option One

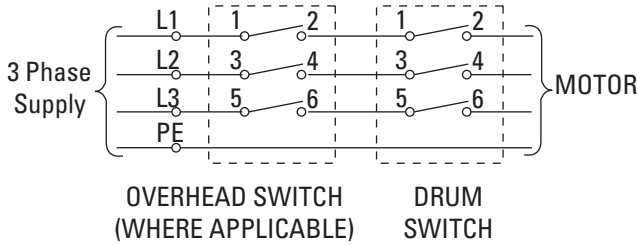
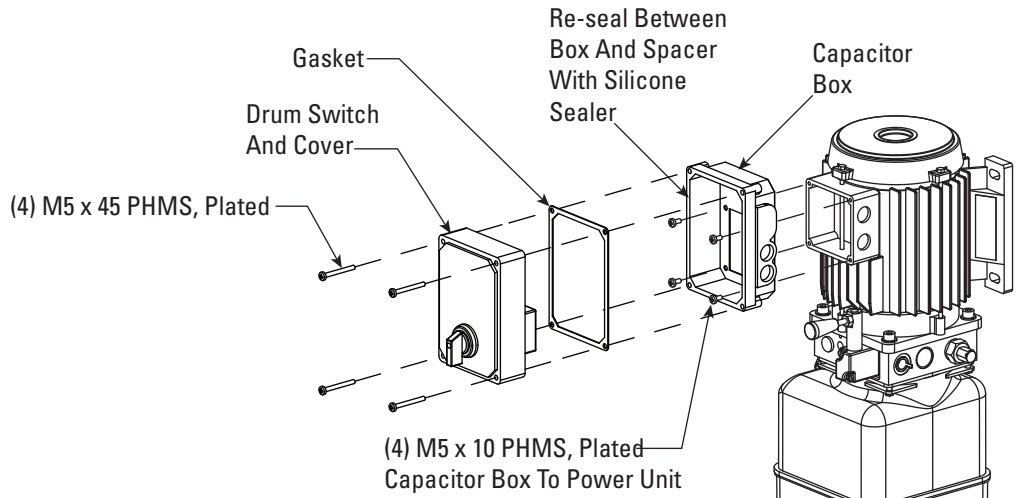

Capacitor Box Attachment Option Two

MOTOR OPERATING DATA TABLE - THREE PHASE	
LINE VOLTAGE	RUNNING MOTOR VOLTAGE RANGE
208-240V 50/60Hz.	197-253V
400V 50Hz.	360-440V
440-480V 50/60Hz.	396V-528V
575V 60Hz.	518V-632V

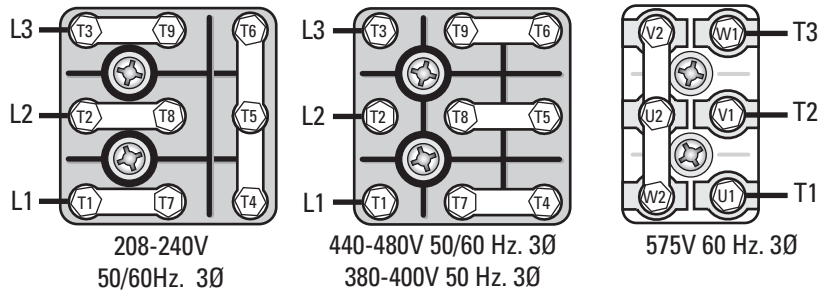

FIGURE B

19. Tighten Lock Ladder Rod Nut located on the top of each posts (Item # 41). This will raise the corner of the lift to adjust for leveling. Each post has this adjustment. Adjust the proper columns to level the lift. Place level on each runway and crossbeam and check for proper levelness.

NOTE: YOU MAY HAVE TO LOOSEN THE NUT UNDER TOP PLATE TO MAKE ADJUSTMENTS.

20. After leveling is complete, tighten the Nut on the Lock Rod underneath the Top Cap on each post. This will lock the Lock Ladder in position.
21. Raise lift off all locks until cables are supporting the lift. Adjust the Cable Nylon Lock Nut (Item # 72) located on the top of each post until lift is level on crossbeams and runways. This will ensure the lift travels up and down level.

NOTE: YOU MAY NEED TO USE LOCKING PLIERS TO HOLD THE CABLE FROM TURNING WHEN ADJUSTING THE NYLON NUT. MAKE SURE THAT THREADS ENGAGE THROUGH NYLON ON EACH NYLON NUT.

22. Reinstall Crossbeam Covers (Items # 24, 25 & 26) Figure # 7 and the bottom Runway Cover (Item # 97) Figure # 4 onto the underside of the Mainside Runway.
23. Install front Wheel Stops (Item # 27) and Foot Plate (Item # 23) with provided hardware as shown in Figure # 7.
24. Install the Drive On Ramps (Item # 20) with Connecting Frame (Item # 21) as shown if Figure # 6.

NOTE:

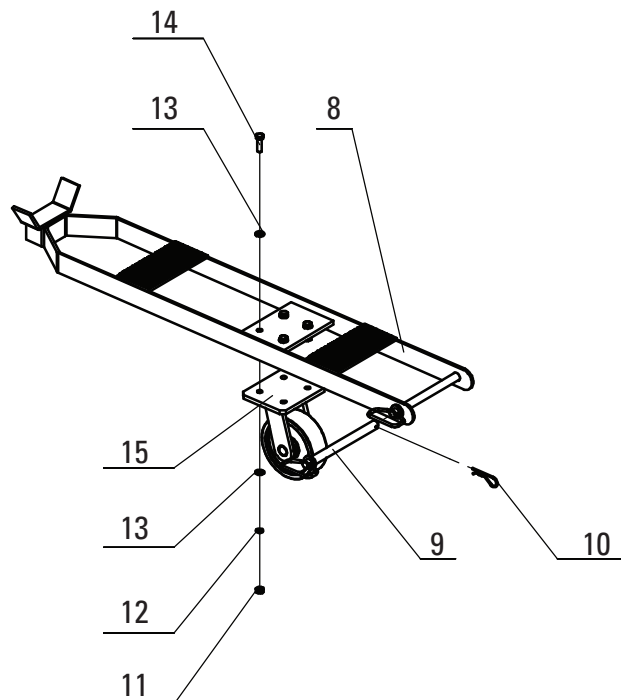

BE SURE TO LUBRICATE ALL CABLE SHEAVES, BEARINGS, AND SHAFTS WITH A GREASE GUN PRIOR TO OPERATING THE LIFT.

CASTER KIT INSTALLATION

1. Raise the Lift two to four feet high
2. Position each of the four Caster assemblies below the Crossbeam rails as shown on page 21 Figure # 6 and in below diagram.
3. Install the four Pivot pins and Cotter pins to secure assembly to each column as shown below.
4. Lower the Lift confirming that the Caster assemblies engage the Crossbeam rails and the four Columns rise to clear the floor.

FOUNDATION REQUIREMENTS

Concrete shall have compression strength of at least 3,000 PSI and a minimum thickness of 4".

CAUTION! DO NOT use on asphalt or similar unstable surfaces.

SPECIAL NOTE

This Lift does not require bolting to the floor
(BUT)

If you choose the option to anchor the lift to the floor please follow the detailed instructions.

FOUNDATION and ANCHORING REQUIREMENTS

1. Concrete shall have compression strength of at least 3,000 PSI and a minimum thickness of 4" in order to achieve a minimum anchor embedment of 3 ¼". NOTE: When using (¾" x 5 ½") long anchors; if the top of the anchor exceeds 2 ¼" above the floor grade, you DO NOT have enough embedment.

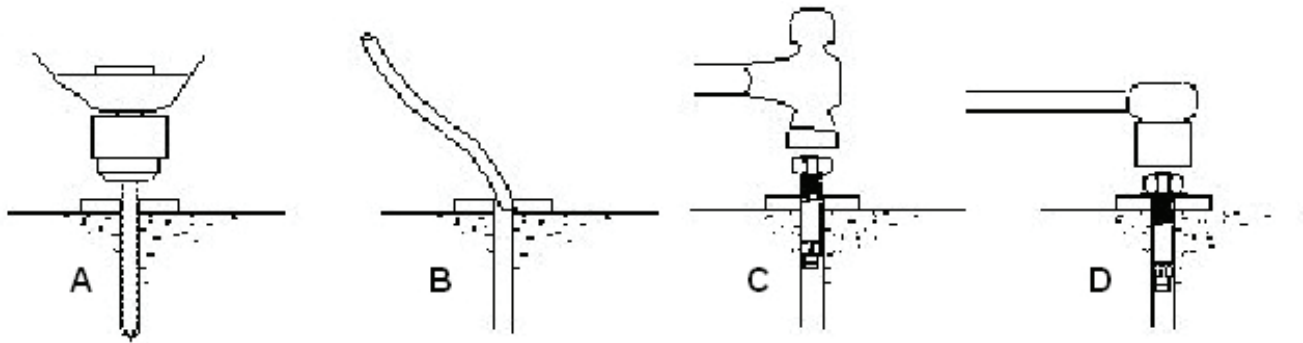

2. Maintain a 6" minimum distance from any slab edge or seam. Hole to hole spacing should be a minimum 6 ½" in any direction. Hole depth should be a minimum of 4".
3. Shim each column base as required until each column is plumb. If one column has to be elevated to match the plane of the other column, full size base shim plates should be used. Torque anchors to 110 ft-lbs. Shim thickness MUST NOT exceed ½" when using the 5 ½" long anchors with the lift. Adjust the column extensions plumb.
4. If anchors do not tighten to 110 ft-lbs. installation torque, replace the concrete under each column base with a 4' x 4' x 6" thick 3,000 PSI minimum concrete pad keyed under and flush with the top of existing floor. Allow concrete to cure before installing lifts and anchors (typically 2 to 3 weeks).

ANCHORING TIP INSTRUCTIONS

CAUTION!

Anchors must be at least 6" from the edge of the slab or any seam.

1. Use a concrete hammer drill with a carbide tip, solid drill bit the same diameter as the anchor, ¾" (.775 to .787 inches diameter). Do not use excessively worn bits or bits which have been incorrectly sharpened.
2. Keep the drill in a perpendicular line while drilling.
3. Let the drill do the work. Do not apply excessive pressure. Lift the drill up and down occasionally to remove residue to reduce binding.
4. Drill the hole to depth equal to the length of anchor. Note: Drilling thru concrete (recommended) will allow the anchor to be driven thru the bottom of foundation if the threads are damaged or if the lift will need to be relocated.
5. For better holding power blow dust from the hole.

6. Place a flat washer and hex nut over threaded end of anchor, leaving approximately ½ inch of thread exposed carefully tap anchor. Do not damage threads. Tap anchor into the concrete until nut and flat washer are against base plate. Do not use an impact wrench to tighten! Tighten the nut, two or three turns on average concrete (28-day cure). If the concrete is very hard only one or two turns may be required. Check each anchor bolt with torque wrench set to 110 foot pounds.

SEISMIC - Varies by location consult
with your structural engineer and
manufacturer's representative.

***The supplied concrete fasteners meet the criteria of the American National Standard "Automotive Lifts - Safety Requirements for Construction, Testing, and Validation" ANSI/ALI ALCTV-2011, and the lift owner is responsible for all charges related to any additional anchoring requirements as specified by local codes. Contact customer service for further information at: 800.640.5438**

OPERATION INSTRUCTIONS

NOTE: ALWAYS CHOCK WHEELS AND SET PARKING BRAKE BEFORE LIFTING VEHICLE!

Only authorized personnel are to operate lift. Read Operating and safety procedures Manual completely before operating lift.

- Properly maintain and inspect lift in accordance to owner' manual.
- Do not operate a lift that is damaged or in need of repair.
- Allow only authorized personnel in the lift bay.
- Stay clear of lift when raising or lowering (no riders).
- Keep hands and feet away from pinch points at all times.
- Never override the lift operating and safety controls.
- If a vehicle is suspected of falling, clear area immediately.
- Do not rock vehicle while positioned on lift.
- Always use safety jack stands when removing or installing heavy components.

Vehicle Loading:

- Position vehicle on lift runways by having another person guide you onto the runways. Check for proper weight distribution (center of gravity should be evenly distributed between columns).
- Set vehicle parking brake and chock tires to prevent vehicle movement.
- Use caution before lifting pickup trucks, suv's and other vehicles. The individual axle weight capacity should not exceed 1/2 of lift capacity.
- Make sure vehicle is neither front nor rear heavy.

Raising Lift:

- Push up switch to raise lift until platform runways clear floor.
- Stop and check for vehicle movement and vehicle weight distribution. If secure raise to desired height.
- Always lower the lift to the nearest lock position by pressing the lower lever to relieve the hydraulic pressure and let the latch set tight in a lock position.
- Never work under a lift that is not in the locked position.

Lowering Lift:

- Clear all obstacles from under lift and vehicle, and ensure only lift operator is in the lift area.
- Stay clear of lift and raise the lift off the safety locks.
- Pull safety latch releases and press the lower lever to begin descent.
- Ensure lift is fully lowered, and having another person guide you, carefully unload the lift by driving off of the lift runways.

*Maximum operation pressure is:
2320 psi for RFP9, EFP9



<p>⚠ CAUTION</p>  <p>Lift to be used by trained operator ONLY.</p>	<p>⚠ CAUTION</p>  <p>Authorized personnel only in lift area.</p>
---	---

The messages and pictographs shown are generic in nature and are meant to generally represent hazards common to all automotive lifts regardless of specific style.

Funding for the development and validation of these labels was provided by the Automotive Lift Institute, PO Box 1519 New York, NY. 10101-1519.

They are protected by copyright. Set of labels may be obtained from ALI or its member companies.

© 1992 by ALI, Inc. ALI/WL200c

<p>SAFETY INSTRUCTIONS</p>  <p>Read operating and safety manuals before using lift.</p>	<p>SAFETY INSTRUCTIONS</p>  <p>Proper maintenance and inspection is necessary for safe operation.</p>
--	--

<p>SAFETY INSTRUCTIONS</p>  <p>Do not operate a damaged lift.</p>	<p><i>The messages and pictographs shown are generic in nature and are meant to generally represent hazards common to all automotive lifts regardless of specific style.</i></p> <p><i>Funding for the development and validation of these labels was provided by the Automotive Lift Institute, PO Box 1519 New York, NY. 10101-1519.</i></p> <p><i>They are protected by copyright. Set of labels may be obtained from ALI or its member companies.</i></p> <p>© 1992 by ALI, Inc. ALI/WL200s</p>
--	--

<p>⚠ WARNING</p>  <p>Clear area if vehicle is in danger of falling.</p>	<p>⚠ WARNING</p>  <p>Remain clear of lift when raising or lowering vehicle.</p>
---	--

<p>⚠ WARNING</p>  <p>Keep clear of pinch points when lift is moving.</p>	<p>⚠ WARNING</p>  <p>Keep feet clear of lift while lowering.</p>
--	---

<p>⚠ WARNING</p>  <p>Do not override self-closing lift controls.</p>	<p>⚠ WARNING</p>  <p>Chock wheel to prevent vehicle movement.</p>
--	--

The messages and pictographs shown are generic in nature and are meant to generally represent hazards common to all automotive lifts regardless of specific style.

Funding for the development and validation of these labels was provided by the Automotive Lift Institute, PO Box 1519 New York, NY. 10101-1519.

They are protected by copyright. Set of labels may be obtained from ALI or its member companies.

© 1992 by ALI, Inc. ALI/WL200w

CAUTION

PAY ATTENTION TO THE LOWERING SPEED OF ALL FOUR CORNERS. MAKE SURE THEY ARE MOVING DOWN AT THE SAME SPEED. STOP LOWERING THE LIFT BY RELEASING THE LOWERING LEVER ON THE POWER UNIT AND MOVING THE LOCK LEVER TO THE LOCK POSITION IF ANY CORNER STOPS MOVING OR IS SLOWER IN DESCENT. ALWAYS LOCK THE LIFT BEFORE GOING UNDER THE VEHICLE. NEVER ALLOW ANYONE TO GO UNDER THE LIFT WHEN RAISING OR LOWERING.

NOTE: It is normal for an empty lift to lower slowly - it may be necessary to add weight.

OWNER / EMPLOYER RESPONSIBILITIES

The Owner / Employer:

- Shall ensure that lift operators are qualified and that they are trained in the safe use and operation of the lift using the manufacturer's operating instructions; ALI/SM01-1, ALI Lifting it Right safety manual; ALI/ST-90 ALI Safety Tips card; ANSI/ALI ALOIM-2008, American National Standard for Automotive Lifts-Safety Requirements for Operation, Inspection and Maintenance; ALI/WL Series, ALI Uniform Warning Label Decals/Placards; and in the case of frame engaging lifts, ALI/LP-GUIDE, Vehicle Lifting Points/Quick Reference Guide for Frame Engaging Lifts.
- Shall establish procedures to periodically inspect the lift in accordance with the lift manufacturer's instructions or ANSI/ALI ALOIM-2008, American National Standard for Automotive Lifts-Safety Requirements for Operation, Inspection and Maintenance; and The Employer Shall ensure that lift inspectors are qualified and that they are adequately trained in the inspection of the lift.
- Shall establish procedures to periodically maintain the lift in accordance with the lift manufacturer's instructions or ANSI/ALI ALOIM-2008, American National Standard for Automotive Lifts-Safety Requirements for Operation, Inspection and Maintenance; and The Employer Shall ensure that lift maintenance personnel are qualified and that they are adequately trained in the maintenance of the lift.
- Shall maintain the periodic inspection and maintenance records recommended by the manufacturer or ANSI/ALI ALOIM-2008, American National Standard for Automotive Lifts-Safety Requirements for Operation, Inspection and Maintenance.
- Shall display the lift manufacturer's operating instructions; ALI/SM 93-1, ALI Lifting it Right safety manual; ALI/ST-90 ALI Safety Tips card; ANSI/ALI ALOIM-2008, American National Standard for Automotive Lifts-Safety Requirements for Operation, Inspection and Maintenance; and in the case of frame engaging lifts, ALI/LP-GUIDE, Vehicle Lifting Points/Quick Reference Guide for Frame Engaging Lifts; in a conspicuous location in the lift area convenient to the operator.
- Shall not modify the lift in any manner without the prior written consent of the manufacturer.
- Shall provide necessary lockout/tagout means for energy sources per ANSI Z244.1-1982 (R1993), Safety Requirements for the Lockout/Tagout of Energy Sources, before beginning any lift repairs.

Lift Lockout/Tagout Procedure

Purpose

This procedure establishes the minimum requirements for the lockout of energy that could cause injury to personnel by the operation of lifts in need of repair or being serviced. All employees shall comply with this procedure.

Responsibility

The responsibility for assuring that this procedure is followed is binding upon all employees and service personnel from outside service companies (i.e., Authorized Installers, contactors, etc.). All employees shall be instructed in the safety significance of the lockout procedure by the facility owner/manager. Each new or transferred employee along with visiting outside service personnel shall be instructed by the owner/manager (or assigned designee) in the purpose and use of the lockout procedure.

Preparation

Employees authorized to perform lockout shall ensure that the appropriate energy isolating device (i.e., circuit breaker, fuse, disconnect, etc.) is identified for the lift being locked out. Other such devices for other equipment may be located in close proximity of the appropriate energy isolating device. If the identity of the device is in question, see the shop supervisor for resolution. Assure that proper authorization is received prior to performing the lockout procedure.

Sequence of Lockout Procedure

- 1) Notify all affected employees that a lockout is being performed and the reason for it.
- 2) Unload the subject lift. Shut it down and assure the disconnect switch is "OFF" if one is provided on the lift.
- 3) The authorized lockout person operates the main energy isolation device removing power to the subject lift.
 - If this is a lockable device, the authorized lockout person places the assigned padlock on the device to prevent its unintentional reactivation. An appropriate tag is applied stating the person's name, at least 3" x 6" in size, an easily noticeable color, and states not to operate device or remove tag.
 - If this device is a non-lockable circuit breaker or fuse, replace with a "dummy" device and tag it appropriately as mentioned above.
- 4) Attempt to operate lift to assure the lockout is working. Be sure to return any switches to the "OFF" position.
- 5) The equipment is now locked out and ready for the required maintenance or service.

Restoring Equipment to Service

- 1) Assure the work on the lift is complete and the area is clear of tools, vehicles, and personnel.
- 2) At this point, the authorized person can remove the lock (or dummy circuit breaker or fuse) & tag and activate the energy isolating device so that the lift may again be placed into operation.

Rules for Using Lockout Procedure

Use the Lockout Procedure whenever the lift is being repaired or serviced, waiting for repair when current operation could cause possible injury to personnel, or for any other situation when unintentional operation could injure personnel. No attempt shall be made to operate the lift when the energy isolating device is locked out.

Operating Conditions

Lift is not intended for outdoor use and has an operating ambient temperature range of 41°-104°F (5°-40°C).

IMPORTANT SAFETY INSTRUCTIONS

When using your garage equipment, basic safety precautions should always be followed, including the following:

1. Read all instructions
2. Care must be taken as burns can occur from touching hot parts.
3. Do not operate equipment with a damaged cord or if the equipment has been dropped or damaged - until it has been examined by a qualified service person.
4. Do not let a cord hang over the edge of the table, bench, or counter or come in contact with hot manifolds or moving fan blades.
5. If an extension cord is necessary, a cord with a current rating equal to or more than that of the equipment should be used. Cords rated for less current than the equipment may overheat.
6. Always unplug equipment from electrical outlet when not in use. Never use the cord to pull the plug from the outlet. Grasp plug and pull to disconnect.
7. Let equipment cool completely before putting away. Loop cord loosely around equipment when storing.
8. To reduce the risk of fire, do not operate equipment in the vicinity of open containers of flammable liquids (gasoline).
9. Adequate ventilation should be provided when working on operating internal combustion engines.
10. Keep hair, loose clothing, fingers, and all parts of body away from moving parts.
11. To reduce the risk of electric shock, do not use on wet surfaces or expose to rain.
12. Use only as described in this manual. Use only manufacturer's recommended attachments.
13. ALWAYS WEAR SAFETY GLASSES. Everyday eyeglasses only have impact resistant lenses, they are not safety glasses.

SAVE THESE INSTRUCTIONS

SAFETY PROCEDURES

- Never allow unauthorized persons to operate lift. Thoroughly train new employees in the use and care of lift.
- Caution - the power unit operates at high pressure.
- Remove passengers before raising vehicle.
- Prohibit unauthorized persons from being in shop area while lift is in use.
- Total lift capacity is 9,000-lbs. Do not exceed this capacity.
- Prior to lifting vehicle, walk around the lift and check for any objects that might interfere with the operation of lift and safety latches; tools, air hoses, shop equipment.
- When approaching the lift with a vehicle, make sure to center the vehicle between the columns. Slowly drive the vehicle up with some one outside the vehicle guiding the driver.
- Prior to lowering vehicle, walk around the lift and check for any objects that might interfere with the operation of lift and safety latches; tools, air hoses, shop equipment.
- Slowly drive the vehicle on and off of the lift. Have some one outside the vehicle guide the driver.

CAUTION NOTE !!

LUBRICATE ALL CABLE SHEAVES, BEARINGS, AND SHAFTS WITH GREASE PRIOR TO OPERATING THE LIFT.

LUBRICATE ALL ON AN ANNUAL BASIS.

Motors and all electrical components are not sealed against the weather and moisture. Install this lift in a protected indoor location. Failure by the owner to provide the recommended shelter could result in unsatisfactory lift performance, property damage, or personal injury.

Read and heed all WARNING, CAUTION and SAFETY INSTRUCTION labels on lift.

PREVENTIVE MAINTENANCE SCHEDULE

The periodic Preventive Maintenance Schedule given is the suggested minimum requirements and minimum intervals; accumulated hours or monthly period, whichever ever comes sooner.

Periodic maintenance is to be performed on a daily, weekly, and yearly basis as given in the following paragraphs.

In the event you need replacement parts, use only Direct Lift replacement parts available from your local Direct Lift distributor.

Do not modify the lift in any manner without the prior written consent of the manufacturer.

WARNING!!

Occupational Safety and Health Administration (OSHA) and the American National Standards Institute (ANSI) requires users to inspect lifting equipment at the start of every shift. These and other periodic inspections are the responsibility of the user.

Failure to perform the daily pre-operational check can result in expensive property damage, lost production time, serious personal injury, and even death. The safety latch system must be checked and working properly before the lift is put to use.

Failure to heed this warning can result in death or serious injury, or damage to equipment. If you hear a noise not associated with normal lift operation, or, if there is any indications of impending lift failure - **CEASE OPERATION IMMEDIATELY!** - Inspect, correct and/or replace parts as required. Use only Direct Lift replacement parts available from your local Direct Lift distributor.

Daily Pre-Operation Check (8-Hours)

- Check safety lock audibly and visually while in operation
- Check safety latches for free movement and full engagement with rack.
- Check hydraulic connections, and hoses for leakage.
- Check cables connections bends, cracks-and for loose fittings.
- Check for frayed cables in both raised and lowered position.
- Check snap rings at all rollers and sheaves.
- Check bolts, nuts, and screws and tighten if needed.
- Check wiring & switches for damage.

- Check floor for stress cracks near columns.
- Check Lubrications on cable sheaves and shafts.

Weekly Maintenance (every 40-Hours)

- IF LIFT IS ANCHORED TO FLOOR - Check anchor bolts torque to 65 ft-lbs for the ¾ in. anchor bolts. Do not use an impact wrench to tighten anchor bolts.
- Check floor for stress cracks near columns
- Check hydraulic oil level.
- Check and tighten bolts, nuts, and screws.
- Check all cable sheaves/assembly for free movement or excessive wear on cable sheave shaft.

Yearly Maintenance

- Lubricate the cable sheave shaft by using grease gun at least once a year after the lift is in service.
- Check for excessive wear of cable. Replace them if necessary.
- Change the hydraulic fluid - good maintenance procedure makes it mandatory to keep hydraulic fluid clean. No hard fast rules can be established; - operating temperature, type of service, contamination levels, filtration, and chemical composition of fluid should be considered. If operating in dusty environment shorter interval may be required.

Special Maintenance Tasks

NOTE: The following items should only be performed by a trained maintenance expert:

- Replacement of hydraulic hoses.
- Replacement of cables and sheaves.
- Replacement or rebuilding air and hydraulic cylinders as required.
- Replacement or rebuilding pumps / motors as required.
- Checking of hydraulic cylinder rod and rod end (threads) for deformation or damage.

CAUTION!!

Relocating or changing components may cause problems. Each component in the system must be compatible; an undersized or restricted line will cause a drop in pressure. All valve, pump, and hose connections should be sealed and/or capped until just prior to use. Air hoses can be used to clean fittings and other components. However, the air supply must be filtered and dry to prevent contamination. Most important is cleanliness; Contamination is the most frequent cause of malfunction or failure of hydraulic equipment.

TROUBLESHOOTING

The common problems that may be encountered and their probable causes are covered in the following paragraphs:

- **Motor Does Not Operate**

Failure of the motor to operate is normally caused by one of the following:

1. Breaker or fuse blown.
2. Faulty wiring connections; call electrician.
3. Defective up button; call electrician for service.

- **Motor Functions but Lift Will Not Rise**

If the motor is functioning, but the lift will not rise do the following in the order given:

1. A piece of trash is under check valve. Push handle down and push the up button at the same time. Hold for 10-15 seconds. This should flush the system.
2. Check the clearance between the plunger valve of the lowering handle. There should be 1/16" clearance.
3. Remove the check valve cover and clean ball and seat.

WARNING!!

Failure to properly relieve pressure in the following step can cause injury to personnel. This lift uses ISO Grade 32 or other good grade non-detergent hydraulic oil at a high hydraulic pressure. Be familiar with its toxicological properties, precautionary measures to take, and first aid measures as stated in the Safety Summary before performing any maintenance with the hydraulic system.

4. Oil level too low. Oil level should be just under the vent cap port when the lift is down. Relieve all hydraulic pressure and add oil as required.

- **Lift Will Not Raise Off of Latches**

1. Motor, pump, or cylinder failure.
2. Contact lift manufacturer's Customer Service.

- **Oil Blows out Breather of Power Unit**

If oil blows out of the breather of the power unit, take the following actions:

1. Oil reservoir overfilled. Relieve all pressure and siphon out hydraulic fluid until at a proper level
2. Lift lowered too quickly while under a heavy load. Lower the lift slowly under heavy loads.

- **Motor Hums and Will Not Run**

If the motor hums but fails to run, take the following actions:

1. Lift overloaded. Remove excessive weight from lift

WARNING!!

The voltages used in the lift can cause death or injury to personnel. In the following steps, make sure that a qualified electrician is used to perform maintenance

2. Faulty wiring..... Call electrician
3. Bad capacitor..... Call electrician
4. Low voltage..... Call electrician

- **Lift Jerks Going Up and Down**

1. If the lift jerks while going up and down, it is usually a sign of air in the hydraulic system. Raise lift all the way to top and return to floor. Repeat 4-6 times. Do not let this overheat power unit.

- **Oil Leaks**

Oil leak causes at the power unit and cylinders are normally caused by the following:

1. Power unit: if the power unit leaks hydraulic oil around the tank-mounting flange check the oil level in the tank. The level should be two inches below the flange of the tank. A screwdriver can be used as a "dipstick".
2. Cylinder - Piston Rod: the rod seal of the cylinder is out. Rebuild or replace the cylinder.
3. Cylinder - Vent: the piston seal of the cylinder is out. Rebuild or replace the cylinder.

- **Lift makes excessive noise / vibrates**

Excessive noise from the lift is normally caused by the following:

1. Cross beam ends are rubbing the columns. Readjustment needed.
2. Cylinder too tight, load lift half capacity and cycle up and down a few times to break in.
3. May have excessive wear on cable sheaves or shafts. Replace them.

Cable Inspection Guide

Maximum Allowable Cable Necking

Nom. Cable Diameters	Max. Reduction in Diameter
Up to 5/16"	1/64"
3/8" to 1/2"	1/32"
9/16" to 3/4"	3/64"
7/8" to 1-1/8"	1/16"
1-1/4" to 1-1/2"	3/32"

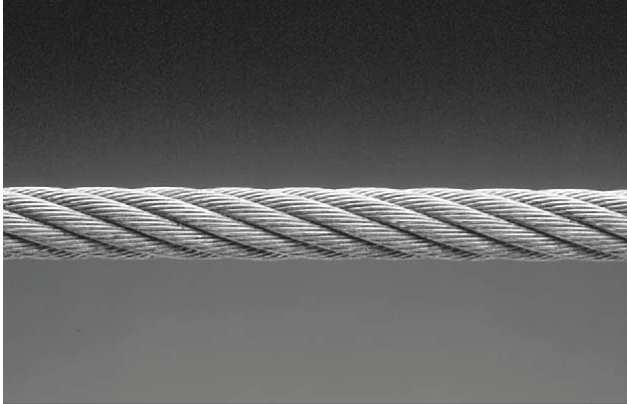

Typical Good Cable



Cable With Broken Wires

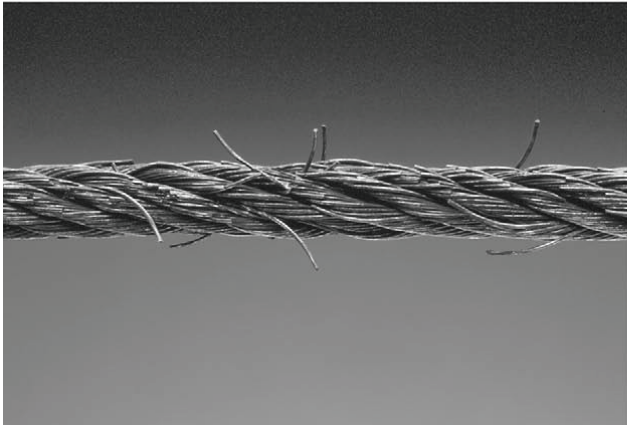

Cable With Severe Corrosion

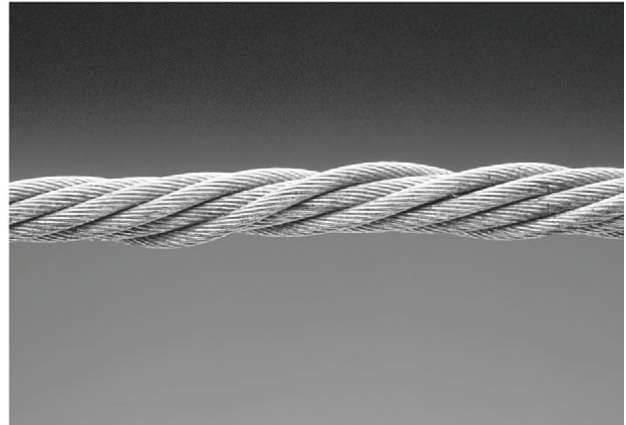

Cable With Necking

Daily Inspection & Maintenance

1. **Cleanliness:** Cables, Columns, Runways and other lift parts should be kept free of corrosive agents, solvents, and road salts. If such agents are spilled or splashed on any lift component, immediately rinse thoroughly with water and wipe down with a clean rag. Spray wire rope cables as required with Penetrating Oil and wipe down.

Failure to keep lift free of corrosive agents and solvents will lead to reduced component service life, cable failure, etc., which could result in property damage and/or personal injury.

2. Fasteners: Check all the attaching bolts and nuts for tightness.
3. Cables: Check wire rope cables for wear or damage. Any cable with broken wires, severe corrosion, excessive stretch, deformed strands, variations in diameter (necking), or any change from its normal appearance, must be replaced. If any cable is found to be in need of replacement, the entire cable set must be replaced immediately. Refer to figures below.
4. Sheaves: Check sheaves (pulleys) for wear or damage, i.e. wobble (tilt), cracks, loose on pin, or excessive noise during operation.
5. Sheave Pins: Check for loose or missing sheave (pulley) pins.
6. Locking Latches and Slack Cable Devices: Watch locking latches and slack cable devices during lift operation to ensure that latches work properly and line up with slots in latch plate located in columns.

Monthly Inspection & Maintenance

1. Cables
 - 1.1 Clean wire rope cables with lift in both lowered and raised position by spraying with Penetrating Oil and wiping the cable down.
 - 1.2 Adjust cables using procedures on following pages.
2. Slack Cable Device: Inspect slack cable devices using procedure on page 5.
3. Column Anchor Bolts: Check column anchor bolts for tightness. Re-torque anchors bolts to 65 ft/lbs. If anchors do not tighten to the required installation torque, replace concrete under each column base per installation instructions. Let concrete cure before installing lifts and anchors.
4. Columns: Look for corrosion, giving special attention to the area at the base of the column. Check severely corroded areas by pecking with an awl or welder's chipping hammer. If column is corroded through at any point it must be replaced immediately. If not corroded through, remove old paint and rust scale, then coat with a high quality corrosion resistant paint.

Daily Inspection & Maintenance

1. Cleanliness: Cables, Columns, Runways and other lift parts should be kept free of corrosive agents, solvents, and road salts. If such agents are spilled or splashed on any lift component, immediately rinse thoroughly with water and wipe down with a clean rag. Spray wire rope cables as required with Penetrating Oil and wipe down.

Failure to keep lift free of corrosive agents and solvents will lead to reduced component service life, cable failure, etc., which could result in property damage and/or personal injury.

5. Sheave Pins: Check for loose or missing sheave (pulley) pins.
6. Locking Latches and Slack Cable Devices: Watch locking latches and slack cable devices during lift operation to ensure that latches work properly and line up with slots in latch plate located in columns.

Monthly Inspection & Maintenance

1. Cables
 - 1.1 Clean wire rope cables with lift in both lowered and raised position by spraying with Penetrating Oil and wiping the cable down.
 - 1.2 Adjust cables using procedures on following pages.
2. Slack Cable Device: Inspect slack cable devices using procedure on page 5.
3. Column Anchor Bolts: Check column anchor bolts for tightness. Re-torque anchors bolts to 65 ft/lbs. If anchors do not tighten to the required installation torque, replace concrete under each column base per installation instructions. Let concrete cure before installing lifts and anchors.
4. Columns: Look for corrosion, giving special attention to the area at the base of the column. Check severely corroded areas by pecking with an awl or welder's chipping hammer. If column is corroded through at any point it must be replaced immediately. If not corroded through, remove old paint and rust scale, then coat with a high quality corrosion resistant paint.

A thorough inspection of the lifting system must be performed quarterly by qualified lift service personnel; more frequently (monthly) under extreme service conditions such as outside installations or high usage (10 or more cycles per day, etc.).

Quarterly Inspection & Maintenance

1. Cables
 - 1.1 Inspect cables in both lowered and raised position. The cables may also be viewed through various inspection holes and openings in yokes and runways. Check all the following:
 - a. That cables have no broken wires visible, reference Daily Inspection & Maintenance.
 - b. That cables are free of severe corrosion and pitting, reference Daily Inspection & Maintenance. A light surface corrosion on exposed outer wires is normal. Penetrating Oil should be applied during monthly periodic inspection.
 - c. That there are no areas on the cable that have a greatly reduced diameter or "necking", reference Daily Inspection & Maintenance. When any cable is found with excessive necking, all cables must be replaced immediately.
 - d. That cables do not have excessive stretch. It is normal for new cable to require adjustment during "break-in", after which small periodic adjustments may be required. However, if a cable that has been in service for 6 months should suddenly require frequent adjustments or has used all the cable adjustment available, all cables must be replaced immediately.

- e. If any cable is found to be in need of replacement, the entire cable set must be replaced immediately.
- f. Cables are expendable items and should be replaced as a set every 20,000 cycles (estimated) or every 6 years, unless earlier replacement is indicated during inspection.

2. Sheaves and Pins

Inspect sheaves and pins in yokes and runways. Sheaves are expendable items. Sheaves and pins should be replaced when worn. Use of sheaves and pins with excessive wear will lead to reduced service life of cables.

2.1 Inspect sheaves (pulleys) in yoke ends with lift in lowered position or resting on the locking latches.

- a. Hold lowering handle down and pull on cable in column to create slack in cables.
- b. Check for excessive side to side wobble. Grasp rim of sheave and attempt to wobble (tilt) side to side. If sheaves wobble (tilt) more than 3/16" (4.8 mm) side to side or move up and down on shaft more than 1/32" (0.8 mm), the sheave and pin (shaft) should be replaced.
- c. Check sheaves and replace if cracks are found.
- d. Check for ease of rotation. If sheaves do not turn freely, the sheave and sheave pin should be removed, inspected, lubricated, and reinstalled or replaced.

2.2 Fully raise lift. Inspect sheaves (pulleys) in runway ends with lift in raised position.

- a. Visually inspect alignment of sheaves, see figure above. Misalignment of sheave(s) indicates excessive wear; the sheave(s) and sheave pin should be removed and inspected. Replace as required.
- b. Hold lowering handle down to lower lift onto latches. Pull on cables under runway to create cable slack.
- c. Check for excessive side to side wobble. Grasp rim of sheave and attempt to wobble (tilt) side to side, refer to figures above. If sheaves wobble (tilt) more than 1/16" (1.6 mm) side to side, or move in and out more than 1/32" (0.8 mm), the sheave and sheave pin (shaft) should be replaced, refer to figures above.

3. Hydraulic Cylinder

Inspect the hydraulic cylinder mounting to the runway. Inspect cylinder and hydraulic hoses for leaks. Repair or replace as required.

1 Check and tighten the hydraulic cylinder rod nuts holding the cable pull bar.

4. TRACKS for Rolling Jack and Oil Drain Pan

Inspect rolling jack/oil drain pan tracks for cleanliness, corrosion, excessive wear or damage. Clean dirty tracks.

WARNING! Worn or damaged tracks must be repaired immediately.

Failure to do so will lead to reduced service life which could result in property damage and/or personal injury.

5. Latch Inspection and Adjustment

Check locking latches for proper operation. Inspect for worn or missing parts. Replace worn or damaged parts

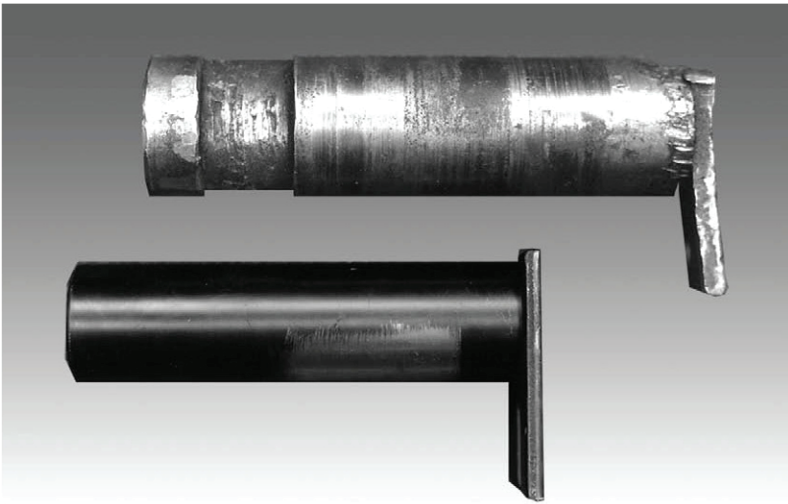
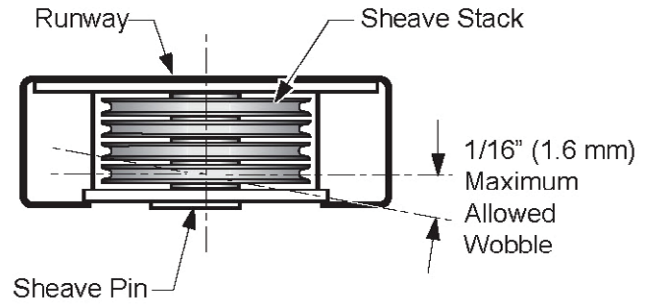
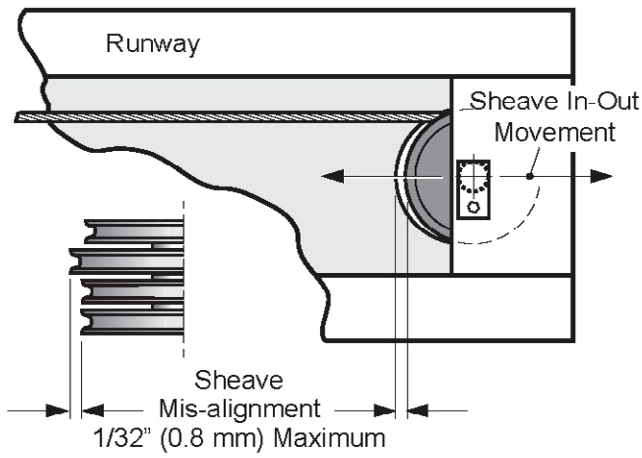

TOP PIN With Excessive Scoring and Wear

BOTTOM PIN With Normal Wear

and adjust as required.

1. Latches

Check latch operation on all four corners.

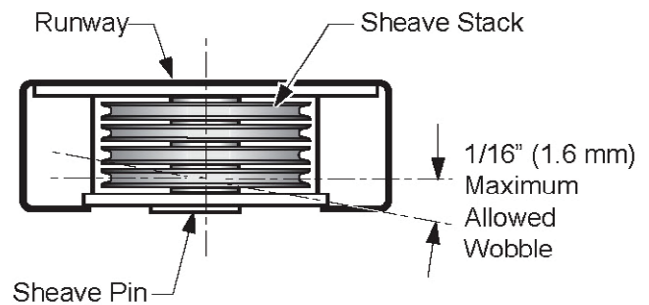
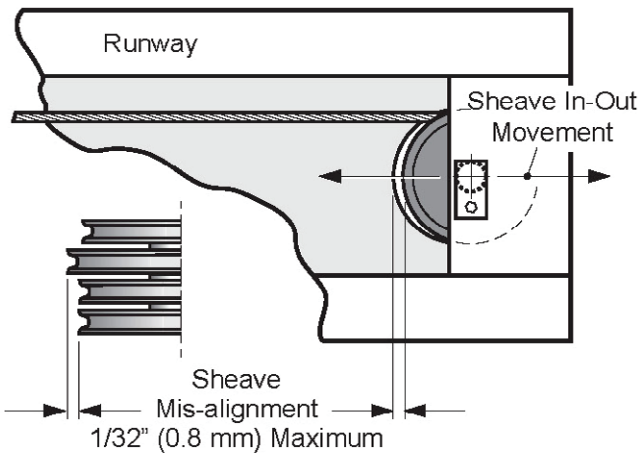

2. Latch and Latch Bar Line-Up

Observe locking latches during lift operation to ensure that all latches line up with slots in latch bar located in all four columns. If not, relocate and/or re-shim columns.

1. Check slack cable devices for proper operation. Inspect for worn or missing parts. Replace worn or damaged parts as required.
2. Observe both locking latches and slack cable devices during lift operation to ensure that all latches line up with slots in latch bar located in all four columns.

Cable Adjustment

1. Initial Adjustment

Adjust cable with lift fully lowered. Loosen jam nut and tighten nut on cable stud on top of column until yoke end is raised 1/4" (6.4 mm) and back off nut one turn. Retighten jam nut. Repeat for all four cables.

2. Final Adjustment

- a. Load a typical vehicle on lift.
- b. Raise lift as high as it will travel (full height). You should hear the locking latches click through all latch slots simultaneously.
- c. Lower lift onto top latch position.
- d. Check clearance:
- e. Starting with the right front column, use a straight edge to mark the position of the yoke bottom on the column.
- f. Raise lift to full height again. Mark second position. If gap between two marks is less than 2", adjust locking latch bar to reach clearance of 2". Repeat for the other three columns.
- g. Adjust locking latch bar adjusting nut so that the bottom of the topmost latch bar slot is at least 2" below locking latch. After adjustment, tighten jam nut underneath column top plate, Fig. 11.
- h. If entire 2" clearance cannot be attained by adjusting the locking latch bar, adjust the cable. Turn cable adjusting nut to raise the locking latch 2" above bottom of latch bar slot. Tighten cable jam nut.
- i. Lower lift and remove vehicle.
- j. Raise the lift to full height. LISTEN and WATCH as the first locking latch clicks into place. Synchronize the other three columns with this column by adjusting their cables so all four latches click at same time. Tighten jam nuts.

When making changes to adjustment nuts on cable end or latch bar stud, always leave at least two threads showing between nut and stud end.

Latches may not click in at the same time when vehicle is being raised. They should be close. Be sure all four corners have passed the locking latch bar slot before lowering lift on locking latches

ILLUSTRATED PARTS LIST

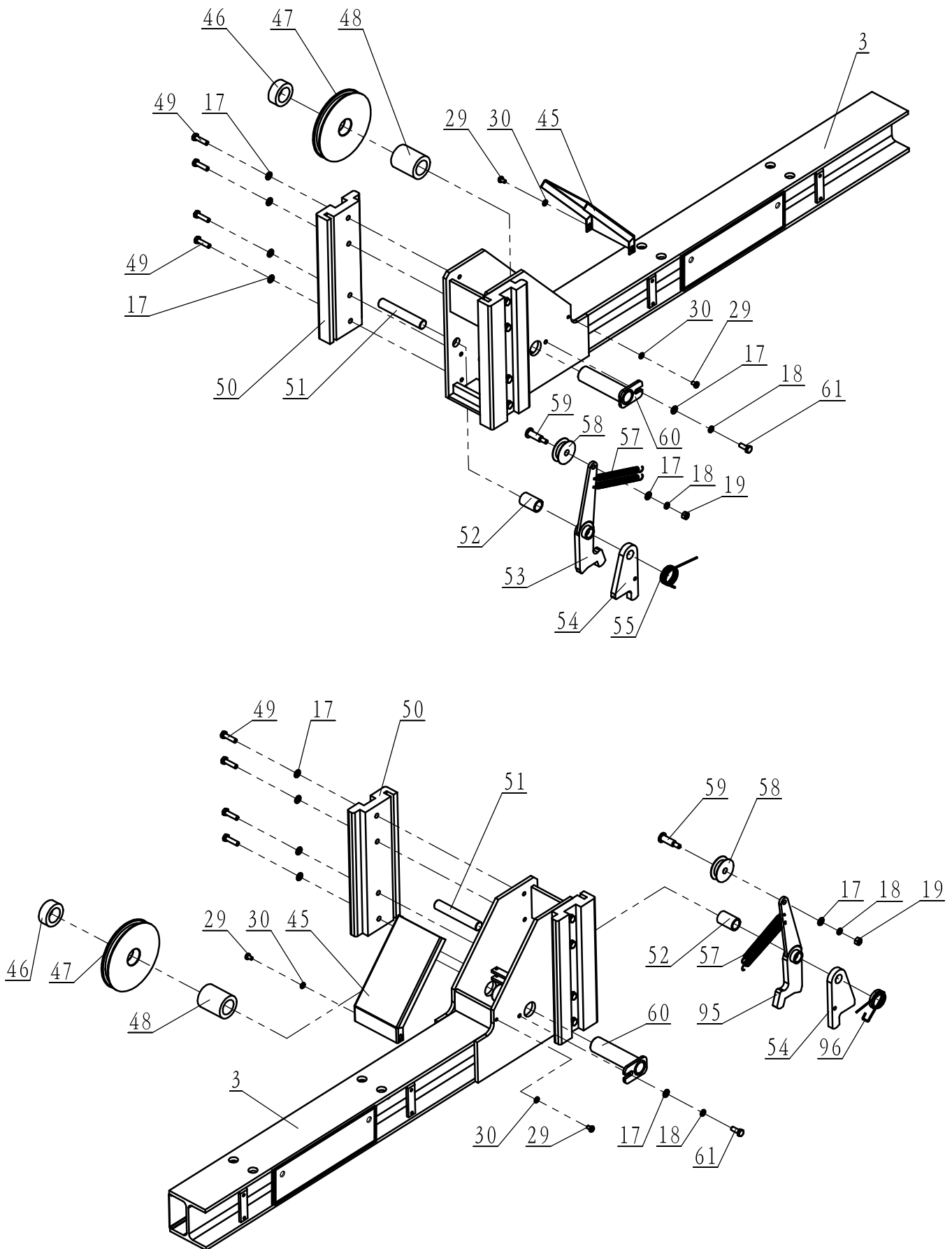

CROSSBEAM / SAFETY LATCH ASSEMBLY - FIGURE # 1

COLUMN & LOCK LADDER – FIGURE # 2

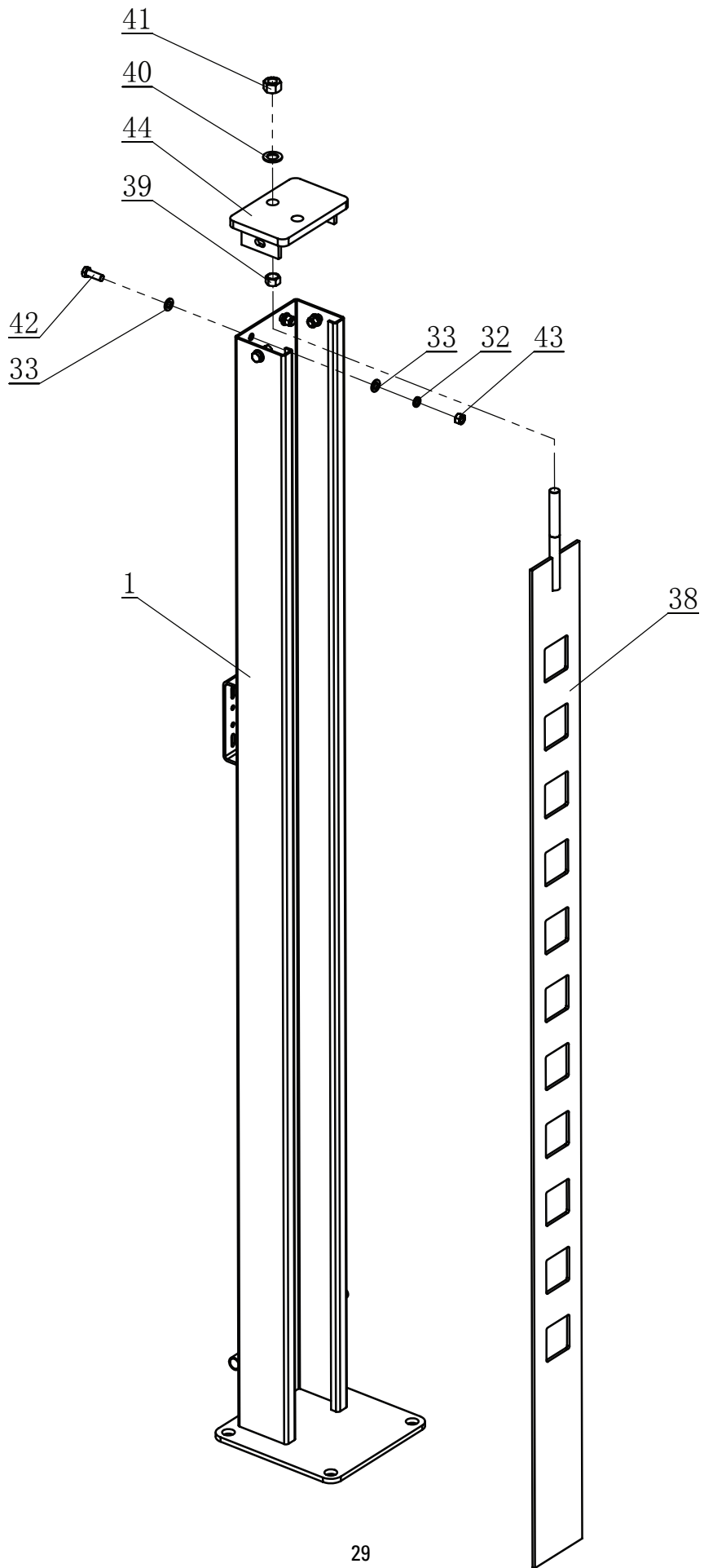

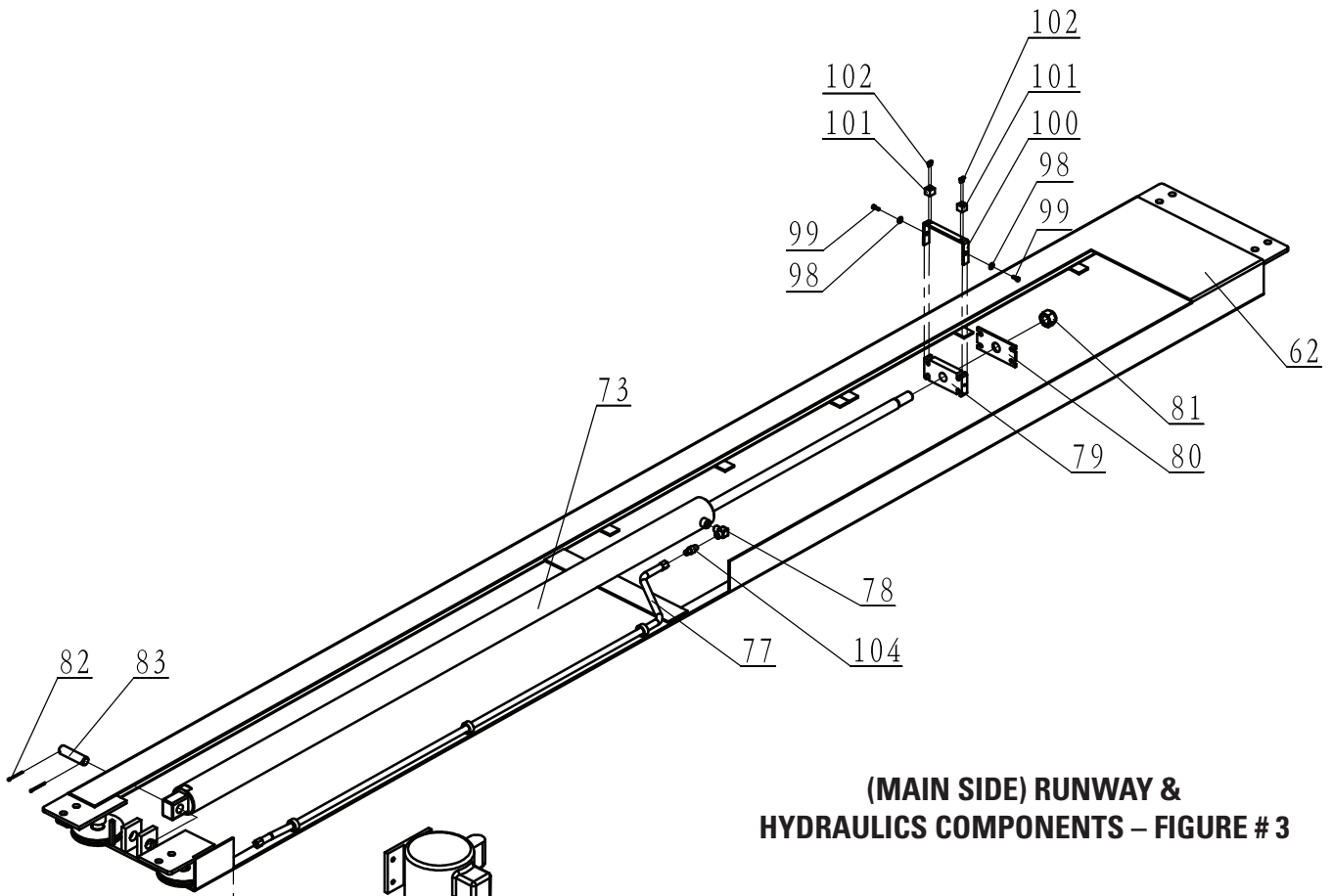

**(MAIN SIDE) RUNWAY &
HYDRAULICS COMPONENTS – FIGURE # 3**

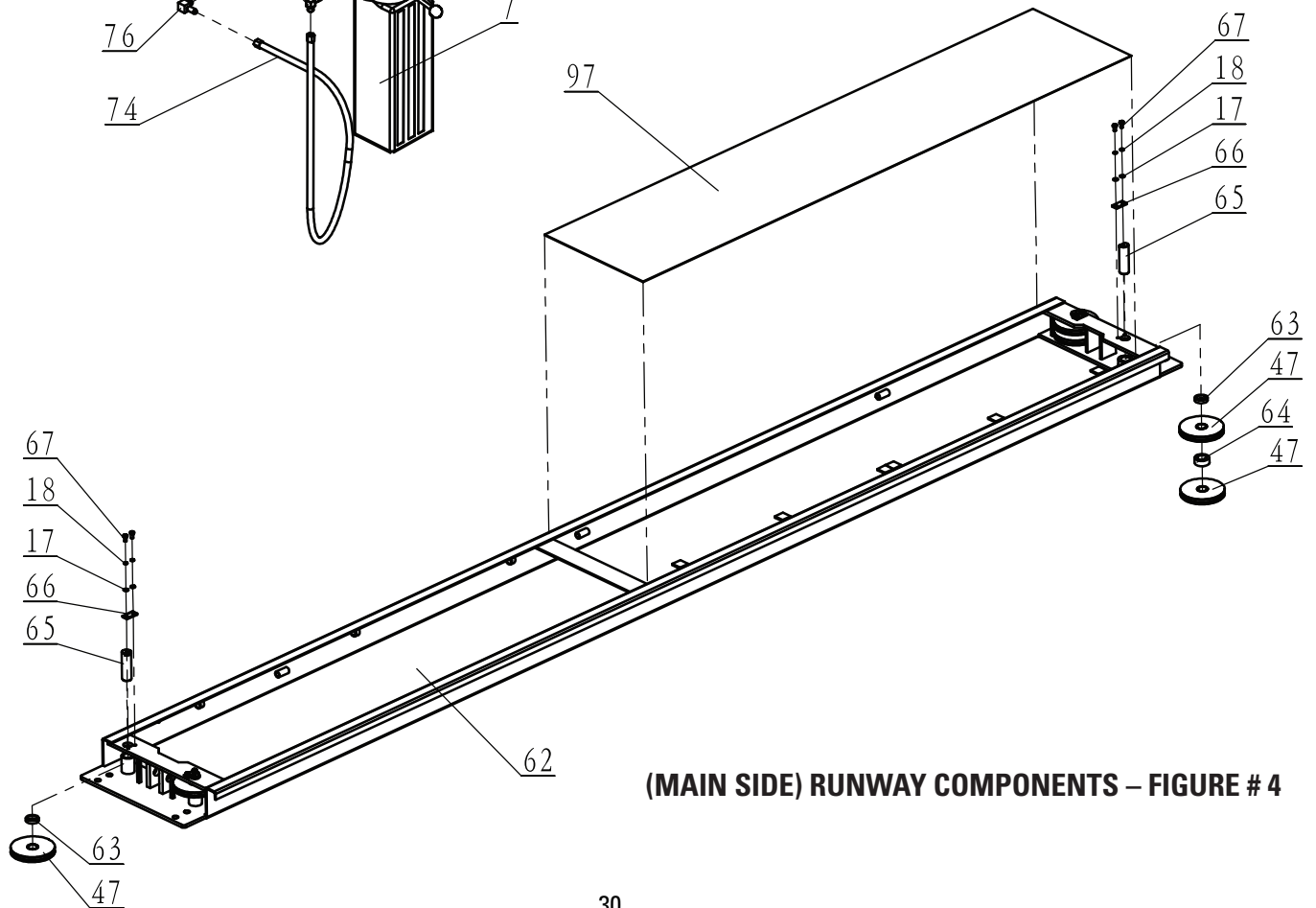

(MAIN SIDE) RUNWAY COMPONENTS – FIGURE # 4

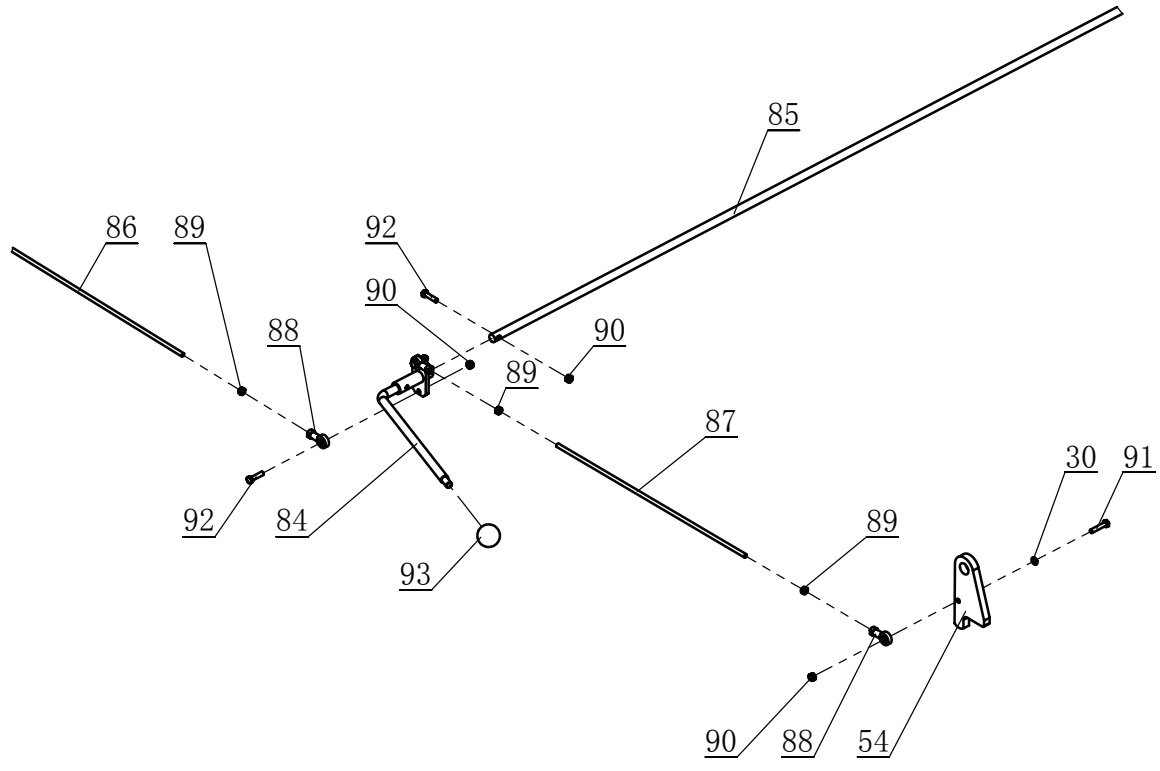
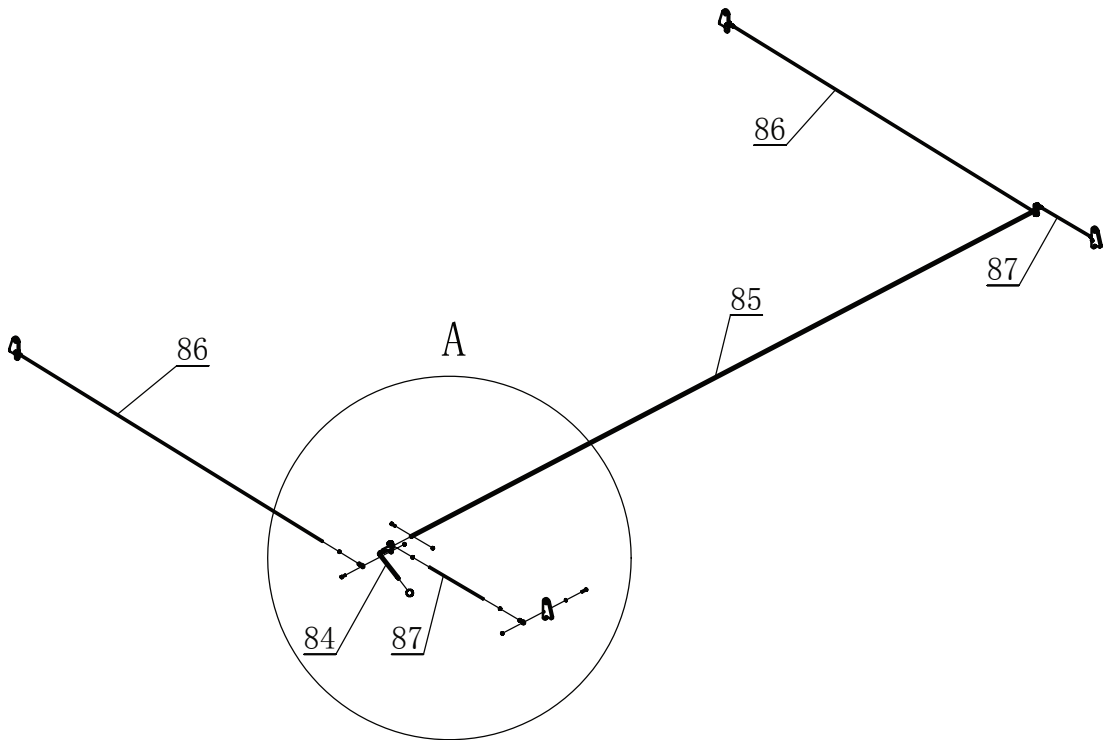

SAFETY LATCH & LINKAGE COMPONENTS – FIGURE # 5

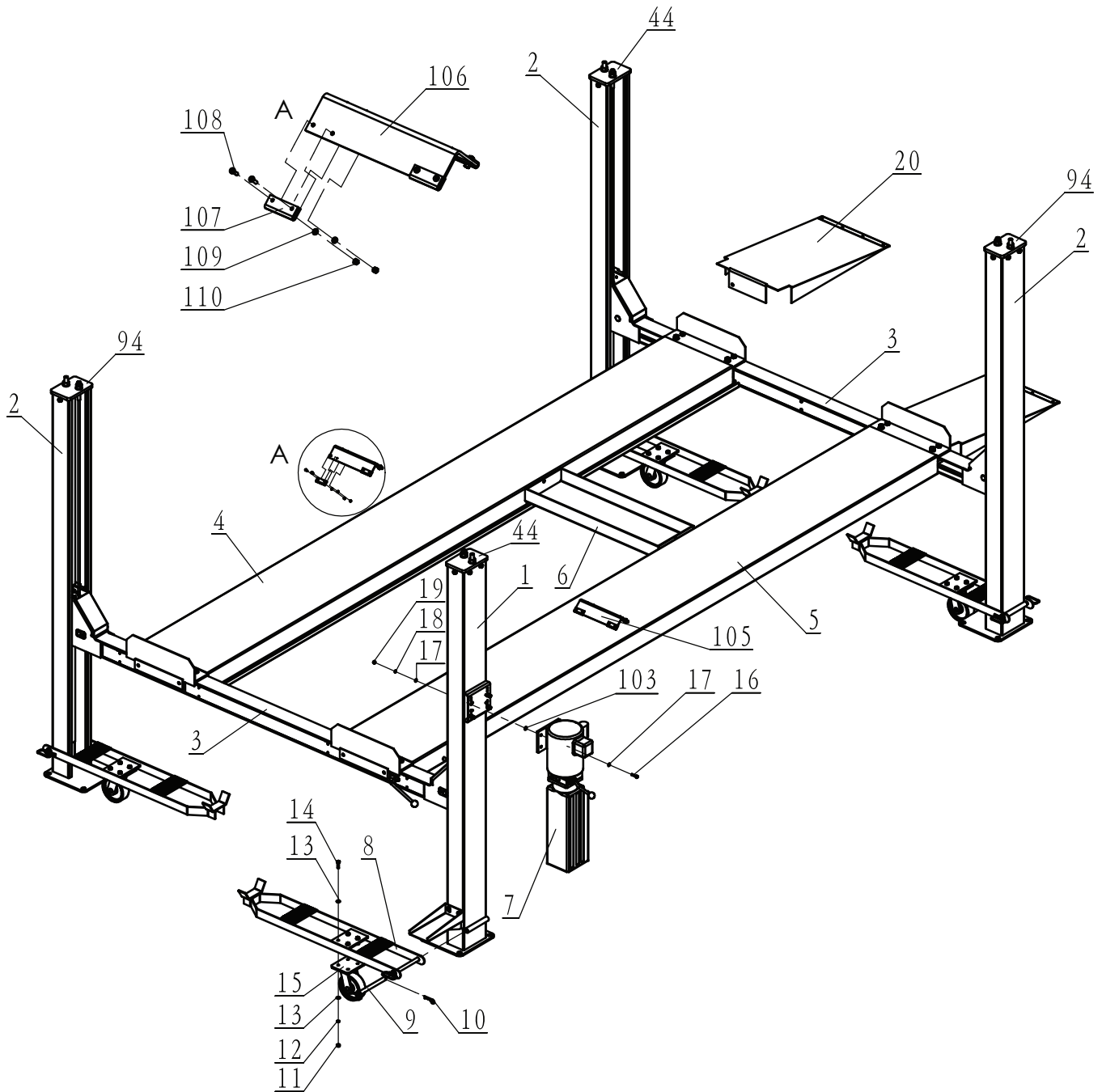

GENERAL ILLUSTRATED PARTS LIST (A) – FIGURE # 6

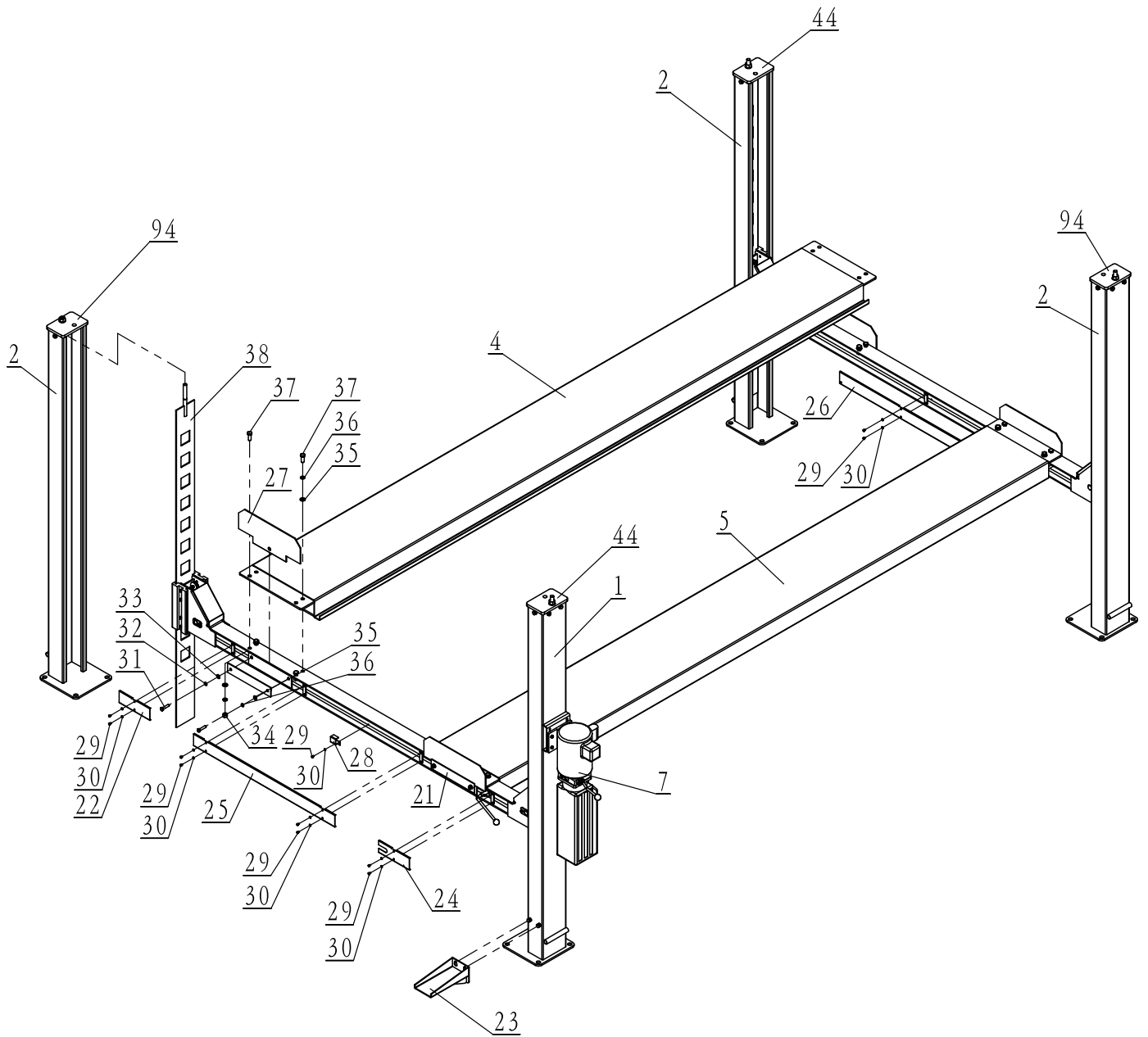

GENERAL ILLUSTRATED PARTS LIST (B) – FIGURE # 7

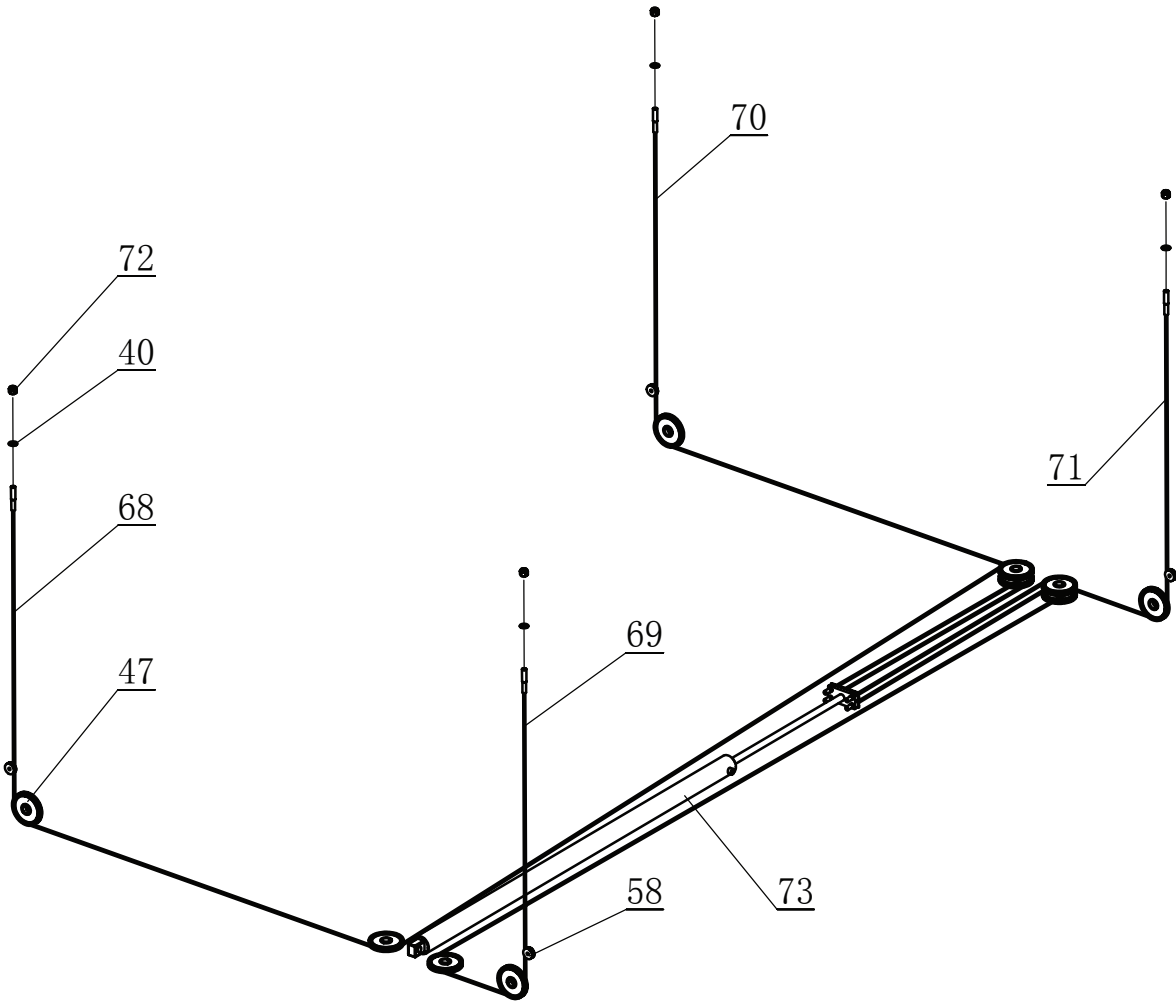

CABLE ROUTING & COMPONENTS - FIGURE # 8

PARTS LIST			
Item#	Part Number	Description	Qty
1	SH4D-1000	COLUMN WELDMENT, POWER UNIT	1
2	SH4D-1100	COLUMN WELDMENT, PIN	3
3	SH4D-2100G	CROSSBEAM WELDMENT	2
4	SH4D-3200G	RUNWAY, PASSENGER SIDE(OFF SIDE)	1
5	SH4D-3000G	RUNWAY, DRIVER SIDE(MAIN SIDE)	1
6	SH4D-8050	JACK TRAY / PARTS BOX	1
7	P3543	HYDRAULIC POWER UNIT - 110VAC	1
8	SH4D-7000	CASTER FRAME	4
9	SH4D-7100	CASTER FRAME PIN	4
10	H4D-5006-3	COTTER PIN	4
11	B30-10	NUT M10	16
12	B40-10	LOCK WASHER Ø10	16
13	B41-10	FLAT WASHER Ø10	32
14	B10-10×35	BOLT M10×35	16
15	B80-6×2A	POLYURETHANE - CASTER WHEEL Ø6"×2"	4
16	B10-8×35	BOLT M8×35	4
17	B41-8	FLAT WASHERØ8	56
18	B40-8	LOCK WASHERØ8	20
19	B30-8	NUT M8	8
20	SH4D-6000G	"DRIVE ON" RAMP	2
21	SH4D-8060G	CONNECTING FRAME	4
22	SH4D-2012G	COVER PLATE C	3
23	SH4D-1600	FOOT PLATE	1
24	SH4D-2011G	COVER PLATE B	1
25	SH4D-2010G	COVER PLATE A	2
26	NH4D-1142	INSIDE COVER PLATE	2
27	SH4D-8001G	WHEEL STOP	2
28	NH4D-4006	BRACKET , CROSSBEAM	2
29	B23-6×10	SCREW M6×10	30
30	B41-6	FLAT WASHERØ6	34
31	B10-12×50	BOLT M12×50	8
32	B40-12	LOCK WASHER Ø12	24
33	B41-12	FLAT WASHERØ12	40
34	B31-16	NUT M16 GRADE 8.8	8
35	B41-16	FLAT WASHERØ16	16
36	B40-16	LOCK WASHERØ16	16
37	B11-16×40	BOLT M16×40 GRADE 8.8	16
38	SH4D-4000HJ	LOCK LADDER	4
39	NH4D-3303	JAM NUT	4
40	B41-20	FLAT WASHERØ20	8
41	B30-20	NUT M20	4
42	B10-12×35	BOLT M12×35	16
43	B30-12	NUT M12	16

Item#	Part Number	Description	Qty
44	SH4D-1500	TOP CAP A	2
45	SH4D-2001	CROSS RAIL, SAFETY LATCH COVER	4
46	NH4D-1012	BUSHING A	4
47	SH4D-2002	CABLE SHEAVE	10
48	NH4D-1013	BUSHING B	4
49	B10-8x30	BOLT M8x30	32
50	SH4D-2004	RUB BLOCK	8
51	NH4D-1009	LATCH SHAFT	4
52	NH4D-1014	BUSHING C	4
53	NH4D-1002	SAFETY LATCH A	2
54	NH4D-1003	LATCH	4
55	NH4D-1004	LATCH SPRING A	2
57	NH4D-1011	SAFETY LATCH SPRING	8
58	NH4D-1005	PLASTIC PULLEY	4
59	NH4D-1006	CABLE SHEAVE B SHAFT	4
60	SH4D-2003	CABLE SHEAVE SHAFT	4
61	B10-8x20	BOLT M8x20	4
62	SH4D-3100G	DRIVER SIDE RUNWAY (MAIN SIDE) WELDMENT	1
63	NH4D-2002	BUSHING E , SPACER	4
64	NH4D-1012	BUSHING F , SPACER	2
65	SH4D-3001	RUNWAY CABLE SHEAVE SHAFT	4
66	NH4D-2005	LOCATING PLATE	4
67	B10-8x16	BOLT M8x16	8
68	SH4D-8020-4	CABLE A-3/8" x365.8"	1
69	SH4D-8020-3	CABLE B-3/8" x306.5"	1
70	SH4D-8020-2	CABLE C-3/8" x185.5"	1
71	SH4D-8020-1	CABLE D-3/8" x126.4"	1
72	B33-3/4"-16	NYLON LOCK NUT 3/4"-16	4
73	YG36-9100G	HYDRAULIC CYLINDER	1
74	1WB-05	HYDRAULIC HOSE A - "WIRE BRADED"	1
75	SW-002(30400-9053YZ)	FITTING WITH O-RING	1
76	H4D-Y003	90 DEGREE, BULKHEAD FITTING	1
77	SH4D-8010	HYDRAULIC HOSE B - 79.5"	1
78	PP7-9802-2	90 DEGREE FITTING	1
79	NH4D-2021	CABLE LOCK PLATE A	1
80	NH4D-2022	CABLE LOCK PLATE B	1
81	B33-27x2	NYLON LOCK NUT M27x2	1
82	B52-4x50	COTTER PIN Ø4x50	2
83	SH4D-8030	CYLINDER PIN	1
84	SH4D-5002	SAFETY RELEASE HANDLE B(HANDLE ROD)	1
85	SH4D-5001	SAFETY RELEASE HANDLE A("T" ROD)	1
86	SH4D-5003	CONNECTING ROD A	2
87	SH4D-5004	CONNECTING ROD B	2
88	B72-6	SWIVER JOINT M6	8

89	B30-6	NUT M6	8
90	B33-6	NYLON LOCK NUT M6	9
91	B10-6×30	BOLT M6×30	4
92	B10-6×25	BOLT M6×25	5
93	B84-35	PLASTIC KNOB Ø35×M10	1
94	SH4D-1500DC	TOP CAP B	2
95	NH4D-1002DC	SAFETY LATCH B	2
96	NH4D-1004DC	LATCH SPRING B	2
97	SH4D-8000	COVER	1
98	B42-6	FENDER WASHER Ø6	2
99	B20-6×16	SCREW M6×16	2
100	NH4D-2030A	CABLE LOCK BRACKET	1
101	NH4D-2030B	BUTTON	2
102	B20-4×8	SCREW M4×8	4
103	30400-1999	WASHER	4
104	SH4D-9200G	THROTTLE	1
105	H4P-R3100	Wheel Chock	2
106	H4P-R3101	Angle Iron	2
107	H4P-R3102	Rubber	8
108	B23-5×16	Discal Head Screw M5×16	8
109	B41-5	Flat Washer Ø5	8
110	B30-5	Nut M5	8
Accessories Included in Four Post 9,000 lb Lift			
Fig# 6	SH4D-7000CK	POLYURETHANE - CASTER KIT - ASSEMBLY	4
n/a	SH4D9PNBKD-DT	DRIP TRAY	4
6	SH4D-8050	JACK TRAY / TOOL BOX	1

NOTES:

NOTES:

