

UL 2215 OIL/WATER SEPARATORS FIBERGLASS STORAGE TANKS



1-877-CSI-TANK
SOLUTIONS
CONTAINMENT



UL 2215 FIBERGLASS OIL/WATER SEPARATORS

Containment Solutions, Inc. (CSI) provides a variety of solutions for oil separation.

CSI offers UL 2215 listed underground fiberglass oil water separators. Many separator suppliers make performance claims, but the UL 2215 standard provides basic construction requirements for the holding vessel as well as performance testing of the actual OWS product line under simulated operating conditions.

The CSI UL 2215 OWS provides the specifier and owner with assurance of product performance and the peace of mind that comes with an independently tested product.



FEATURES

Fiberglass Construction

Enhanced Coalescer System

Removable Plates for Cleaning

30 Year Structural & Corrosion Warranty

Full Line of Accessories

UL 1316 Designed Vessel

UL 2215 Listed OWS

Single-Wall & Double-Wall

BENEFITS

Corrosion resistance without coatings or protection systems.

M-shaped Oleophilic inclined corrugated parallel plates to maximize separation and solids drop out. Design minimizes maintenance requirements.

Simplifies cleaning process when necessary.

Tank vessel 30 year warranty assures long term performance.

Electronics and pump out systems make specifying a system design easier.

The vessel is designed and manufactured to the stringent performance requirements of UL 1316.

UL Listing provides independent verification of performance of the OWS.

UL listed OWS available in single-wall and double-wall construction.

CSI Fiberglass UL 2215 Oil / Water Separators are available in single-wall and double-wall design, ranging from 1,000 to 40,000 gallon capacities.

UL 2215 MODEL OIL WATER SEPARATOR

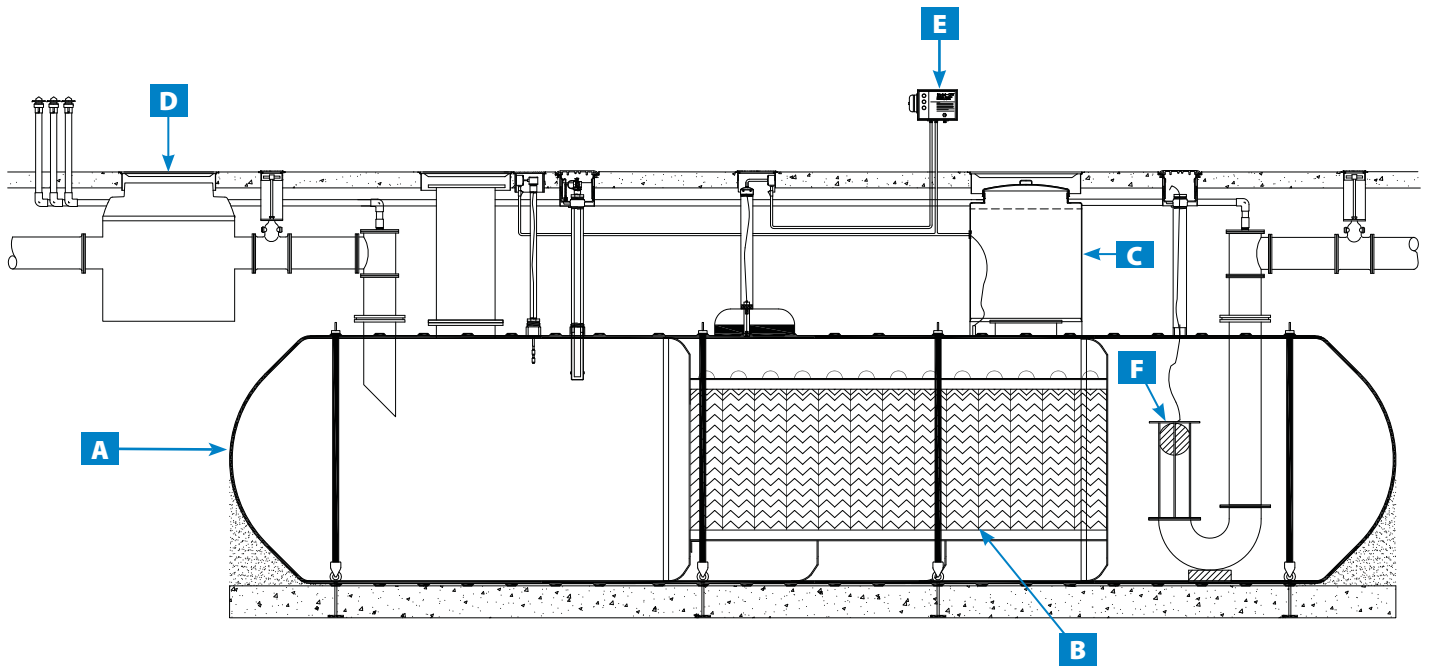

- A** Double-Wall Oil / Water Separator
- B** Coalescer Packs
- C** Tank Sump
- D** Drop Out Box
- E** Control Panel with Alarm
- F** Oil Stop Valve

4' Diameter UL 2215 Model

| # of Plate Packs | Flow Rate | | | Tank Capacity (Gallons) | Oil Storage Capacity (Gallons) | Oil Spill Capacity (Gallons) | Inlet/Outlet Nozzle Size | Nominal Length | | Nominal Weight (lbs) | |
|------------------|-----------|----------|----------|-------------------------|--------------------------------|------------------------------|--------------------------|----------------|-------------|----------------------|-------------|
| | .85 S.G. | .90 S.G. | .95 S.G. | | | | | Single-Wall | Double-Wall | Single-Wall | Double-Wall |
| 1 | 15 | 11 | 5 | 935 | 168 | 748 | 4" | 10' 8" | 10' 9" | 1,275 | 1,855 |
| 2 | 30 | 23 | 10 | 935 | 168 | 748 | 4" | 10' 8" | 10' 9" | 1,315 | 1,895 |
| 3 | 46 | 34 | 15 | 1,044 | 188 | 835 | 4" | 11' 10" | 11' 11" | 1,395 | 2,015 |
| 4 | 61 | 46 | 20 | 1,044 | 188 | 835 | 4" | 11' 10" | 11' 11" | 1,475 | 2,135 |
| 5 | 76 | 57 | 25 | 1,224 | 220 | 979 | 4" | 13' 9" | 13' 10" | 1,555 | 2,255 |
| 6 | 91 | 69 | 31 | 1,514 | 273 | 1,211 | 4" | 16' 10" | 16' 11" | 1,845 | 2,665 |
| 7 | 106 | 80 | 36 | 1,608 | 289 | 1,286 | 4" | 17' 10" | 17' 11" | 1,925 | 2,785 |
| 8 | 122 | 92 | 41 | 1,702 | 306 | 1,362 | 4" | 18' 10" | 18' 11" | 2,005 | 2,905 |
| 9 | 137 | 103 | 46 | 1,796 | 323 | 1,437 | 4" | 19' 10" | 19' 11" | 2,085 | 3,025 |
| 10 | 152 | 115 | 51 | 1,890 | 340 | 1,512 | 6" | 20' 10" | 20' 11" | 2,165 | 3,145 |
| 11 | 167 | 126 | 56 | 1,984 | 357 | 1,587 | 6" | 21' 10" | 21' 11" | 2,245 | 3,265 |
| 12 | 182 | 138 | 61 | 2,078 | 374 | 1,662 | 6" | 22' 10" | 22' 11" | 2,325 | 3,385 |

6' Diameter UL 2215 Model

| # of Plate Packs | Flow Rate | | | Tank Capacity (Gallons) | Oil Storage Capacity (Gallons) | Oil Spill Capacity (Gallons) | Inlet/Outlet Nozzle Size | Nominal Length | | Nominal Weight (lbs) | |
|------------------|-----------|----------|----------|-------------------------|--------------------------------|------------------------------|--------------------------|----------------|-------------|----------------------|-------------|
| | .85 S.G. | .90 S.G. | .95 S.G. | | | | | Single-Wall | Double-Wall | Single-Wall | Double-Wall |
| 1 | 37 | 28 | 13 | 3,319 | 471 | 2,655 | 4" | 16' 8" | 16' 9" | 2,695 | 4,480 |
| 2 | 75 | 56 | 25 | 3,319 | 471 | 2,655 | 4" | 16' 8" | 16' 9" | 2,785 | 4,570 |
| 3 | 112 | 84 | 38 | 3,319 | 471 | 2,655 | 6" | 16' 8" | 16' 9" | 2,875 | 4,660 |
| 4 | 149 | 113 | 50 | 3,319 | 471 | 2,655 | 6" | 16' 8" | 16' 9" | 2,965 | 4,750 |
| 5 | 186 | 141 | 63 | 3,619 | 513 | 2,895 | 6" | 18' 1" | 18' 2" | 3,130 | 4,985 |
| 6 | 224 | 169 | 75 | 4,482 | 635 | 3,586 | 6" | 22' 2" | 22' 3" | 3,345 | 5,560 |
| 7 | 261 | 197 | 88 | 4,482 | 635 | 3,586 | 8" | 22' 2" | 22' 3" | 3,435 | 5,650 |
| 8 | 298 | 225 | 100 | 4,817 | 683 | 3,854 | 8" | 23' 9" | 23' 10" | 3,600 | 5,885 |
| 9 | 335 | 253 | 113 | 5,064 | 718 | 4,051 | 8" | 24' 11" | 25' | 3,765 | 6,120 |
| 10 | 373 | 281 | 125 | 5,469 | 775 | 4,375 | 8" | 26' 10" | 26' 11" | 3,930 | 6,355 |
| 11 | 410 | 309 | 138 | 5,469 | 775 | 4,375 | 8" | 26' 10" | 26' 11" | 4,020 | 6,445 |
| 12 | 447 | 338 | 150 | 5,769 | 818 | 4,615 | 10" | 28' 3" | 28' 4" | 4,185 | 6,680 |
| 13 | 484 | 366 | 163 | 6,051 | 858 | 4,841 | 10" | 29' 7" | 29' 8" | 4,350 | 6,915 |
| 14 | 522 | 394 | 175 | 6,333 | 898 | 5,066 | 10" | 30' 11" | 31' | 4,515 | 7,150 |
| 15 | 559 | 422 | 188 | 6,333 | 898 | 5,066 | 10" | 30' 11" | 31' | 4,605 | 7,240 |
| 16 | 596 | 450 | 200 | 6,632 | 940 | 5,306 | 10" | 32' 4" | 32' 5" | 4,770 | 7,475 |
| 17 | 633 | 478 | 213 | 6,932 | 983 | 5,546 | 10" | 33' 9" | 33' 10" | 4,935 | 7,710 |
| 18 | 671 | 506 | 225 | 6,932 | 983 | 5,546 | 10" | 33' 9" | 33' 10" | 5,025 | 7,800 |
| 19 | 708 | 534 | 238 | 7,161 | 1,015 | 5,729 | 10" | 34' 10" | 34' 11" | 5,190 | 8,035 |
| 20 | 745 | 563 | 250 | 7,461 | 1,058 | 5,969 | 12" | 36' 3" | 36' 4" | 5,355 | 8,270 |
| 21 | 782 | 591 | 263 | 7,796 | 1,105 | 6,237 | 12" | 37' 10" | 37' 11" | 5,520 | 8,505 |
| 22 | 820 | 619 | 275 | 7,796 | 1,105 | 6,237 | 12" | 37' 10" | 37' 11" | 5,610 | 8,595 |
| 23 | 857 | 647 | 288 | 8,042 | 1,140 | 6,434 | 12" | 39' | 39' 1" | 5,775 | 8,830 |
| 24 | 894 | 675 | 300 | 8,395 | 1,190 | 6,716 | 12" | 40' 8" | 40' 9" | 5,940 | 9,065 |
| 25 | 931 | 703 | 313 | 8,395 | 1,190 | 6,716 | 12" | 40' 8" | 40' 9" | 6,030 | 9,155 |
| 26 | 969 | 731 | 325 | 8,695 | 1,233 | 6,956 | 12" | 42' 1" | 42' 2" | 6,195 | 9,390 |
| 27 | 1,006 | 759 | 338 | 9,029 | 1,280 | 7,223 | 12" | 43' 8" | 43' 9" | 6,360 | 9,625 |
| 28 | 1,043 | 788 | 350 | 9,029 | 1,280 | 7,223 | 14" | 43' 8" | 43' 9" | 6,450 | 9,715 |
| 29 | 1,080 | 816 | 363 | 9,276 | 1,315 | 7,421 | 14" | 44' 10" | 44' 11" | 6,615 | 9,755 |
| 30 | 1,118 | 844 | 375 | 9,558 | 1,355 | 7,646 | 14" | 46' 2" | 46' 3" | 6,780 | 9,950 |
| 31 | 1,155 | 872 | 388 | 9,858 | 1,397 | 7,886 | 14" | 47' 7" | 47' 8" | 6,945 | 10,185 |
| 32 | 1,192 | 900 | 400 | 9,858 | 1,397 | 7,886 | 14" | 47' 7" | 47' 8" | 7,110 | 10,420 |

8' Diameter UL 2215 Model

| # of Plate Packs | Flow Rate | | | Tank Capacity (Gallons) | Oil Storage Capacity (Gallons) | Oil Spill Capacity (Gallons) | Inlet/Outlet Nozzle Size | Nominal Length | | Nominal Weight (lbs) | |
|------------------|-----------|----------|----------|-------------------------|--------------------------------|------------------------------|--------------------------|----------------|-------------|----------------------|-------------|
| | .85 S.G. | .90 S.G. | .95 S.G. | | | | | Single-Wall | Double-Wall | Single-Wall | Double-Wall |
| 1 | 48 | 37 | 16 | 6,386 | 777 | 5,109 | 4" | 20' 10" | 20' 11" | 3,730 | 6,530 |
| 2 | 97 | 73 | 33 | 6,386 | 777 | 5,109 | 4" | 20' 10" | 20' 11" | 3,970 | 6,650 |
| 3 | 145 | 110 | 49 | 6,386 | 777 | 5,109 | 4" | 20' 10" | 20' 11" | 4,210 | 6,780 |
| 4 | 194 | 146 | 65 | 6,386 | 777 | 5,109 | 6" | 20' 10" | 20' 11" | 4,450 | 6,900 |
| 5 | 242 | 183 | 81 | 6,386 | 777 | 5,109 | 6" | 20' 10" | 20' 11" | 4,690 | 7,280 |
| 6 | 291 | 220 | 98 | 7,796 | 948 | 6,237 | 8" | 24' 11" | 25' | 5,350 | 8,850 |
| 7 | 339 | 256 | 114 | 8,314 | 1,011 | 6,651 | 8" | 26' 5" | 26' 6" | 5,590 | 9,230 |
| 8 | 388 | 293 | 130 | 8,847 | 1,076 | 7,078 | 8" | 27' 11" | 28' | 5,940 | 9,610 |
| 9 | 436 | 329 | 146 | 8,847 | 1,076 | 7,078 | 8" | 27' 11" | 28' | 6,060 | 9,990 |
| 10 | 485 | 366 | 163 | 9,264 | 1,127 | 7,411 | 10" | 29' 2" | 29' 3" | 6,300 | 10,370 |
| 11 | 533 | 403 | 179 | 9,897 | 1,203 | 7,918 | 10" | 31' | 31' 1" | 6,660 | 10,870 |
| 12 | 582 | 439 | 195 | 10,357 | 1,259 | 8,286 | 10" | 32' 4" | 32' 5" | 6,900 | 11,250 |
| 13 | 630 | 476 | 211 | 10,357 | 1,259 | 8,286 | 10" | 32' 4" | 32' 5" | 6,900 | 11,630 |
| 14 | 678 | 512 | 228 | 10,847 | 1,319 | 8,678 | 10" | 33' 9" | 33' 10" | 7,020 | 12,010 |
| 15 | 727 | 549 | 244 | 11,307 | 1,375 | 9,046 | 12" | 35' 1" | 35' 2" | 7,260 | 12,390 |
| 16 | 775 | 586 | 260 | 11,307 | 1,375 | 9,046 | 12" | 35' 1" | 35' 2" | 7,500 | 12,770 |
| 17 | 824 | 622 | 277 | 11,796 | 1,434 | 9,437 | 12" | 36' 6" | 36' 7" | 7,740 | 13,150 |
| 18 | 872 | 659 | 293 | 12,228 | 1,487 | 9,782 | 12" | 37' 9" | 37' 10" | 7,980 | 13,530 |
| 19 | 921 | 695 | 306 | 12,746 | 1,550 | 10,197 | 12" | 39' 3" | 39' 4" | 8,220 | 13,910 |
| 20 | 969 | 732 | 325 | 12,746 | 1,550 | 10,197 | 12" | 39' 3" | 39' 4" | 8,340 | 14,030 |
| 21 | 1,018 | 769 | 342 | 13,091 | 1,592 | 10,473 | 12" | 40' 3" | 40' 4" | 8,580 | 14,410 |
| 22 | 1,066 | 805 | 358 | 13,091 | 1,592 | 10,473 | 14" | 40' 3" | 40' 4" | 8,700 | 14,530 |
| 23 | 1,115 | 842 | 374 | 13,595 | 1,653 | 10,876 | 14" | 41' 8" | 41' 9" | 8,940 | 14,910 |
| 24 | 1,163 | 878 | 390 | 14,127 | 1,718 | 11,302 | 14" | 43' 3" | 43' 4" | 9,180 | 15,290 |
| 25 | 1,212 | 915 | 407 | 14,732 | 1,791 | 11,786 | 14" | 45' | 45' 1" | 9,420 | 15,670 |
| 26 | 1,260 | 951 | 423 | 15,221 | 1,851 | 12,177 | 14" | 46' 5" | 46' 6" | 9,660 | 16,050 |
| 27 | 1,308 | 988 | 439 | 15,221 | 1,851 | 12,177 | 14" | 46' 5" | 46' 6" | 9,780 | 16,170 |
| 28 | 1,357 | 1,025 | 455 | 15,681 | 1,907 | 12,545 | 14" | 47' 9" | 47' 10" | 10,020 | 16,550 |
| 29 | 1,405 | 1,061 | 472 | 16,171 | 1,966 | 12,937 | 14" | 49' 2" | 49' 3" | 10,260 | 16,930 |
| 30 | 1,454 | 1,098 | 488 | 16,631 | 2,022 | 13,305 | 16" | 50' 6" | 50' 7" | 10,500 | 17,310 |
| 31 | 1,502 | 1,134 | 504 | 16,631 | 2,022 | 13,305 | 16" | 50' 6" | 50' 7" | 10,620 | 17,430 |
| 32 | 1,551 | 1,171 | 521 | 17,120 | 2,082 | 13,696 | 16" | 51' 10" | 51' 11" | 10,860 | 17,810 |
| 33 | 1,599 | 1,208 | 537 | 17,580 | 2,138 | 14,064 | 16" | 53' 3" | 53' 4" | 11,100 | 18,190 |
| 34 | 1,648 | 1,244 | 553 | 17,580 | 2,138 | 14,064 | 16" | 53' 3" | 53' 4" | 11,220 | 18,310 |
| 35 | 1,696 | 1,281 | 569 | 18,041 | 2,194 | 14,433 | 16" | 54' 7" | 54' 8" | 11,460 | 18,690 |
| 36 | 1,745 | 1,317 | 586 | 18,530 | 2,253 | 14,824 | 16" | 56' | 56' 1" | 11,700 | 19,070 |
| 37 | 1,793 | 1,354 | 602 | 18,991 | 2,309 | 15,193 | 16" | 57' 4" | 57' 5" | 11,940 | 19,450 |
| 38 | 1,842 | 1,391 | 618 | 18,991 | 2,309 | 15,193 | 16" | 57' 4" | 57' 5" | 12,060 | 19,570 |
| 39 | 1,890 | 1,427 | 634 | 19,509 | 2,372 | 15,607 | 18" | 58' 10" | 58' 11" | 12,300 | 19,950 |
| 40 | 1,938 | 1,464 | 651 | 19,509 | 2,372 | 15,607 | 18" | 58' 10" | 58' 11" | 12,420 | 20,070 |
| 41 | 1,987 | 1,500 | 667 | 19,998 | 2,432 | 15,998 | 18" | 60' 3" | 60' 4" | 12,660 | 20,450 |
| 42 | 2,035 | 1,537 | 683 | 20,458 | 2,488 | 16,366 | 18" | 61' 7" | 61' 8" | 12,900 | 20,830 |

10' Diameter UL 2215 Model

| # of Plate Packs | Flow Rate | | | Tank Capacity (Gallons) | Oil Storage Capacity (Gallons) | Oil Spill Capacity (Gallons) | Inlet/Outlet Nozzle Size | Nominal Length | | Nominal Weight (lbs) | |
|------------------|-----------|----------|----------|-------------------------|--------------------------------|------------------------------|--------------------------|----------------|-------------|----------------------|-------------|
| | .85 S.G. | .90 S.G. | .95 S.G. | | | | | Single-Wall | Double-Wall | Single-Wall | Double-Wall |
| 1 | 67 | 51 | 22 | 14,297 | 1,314 | 11,438 | 6" | 27' 9" | 27' 10" | 5,920 | 12,010 |
| 2 | 134 | 101 | 45 | 14,297 | 1,314 | 11,438 | 6" | 27' 9" | 27' 10" | 6,040 | 12,130 |
| 3 | 201 | 152 | 67 | 14,297 | 1,314 | 11,438 | 6" | 27' 9" | 27' 10" | 6,160 | 12,250 |
| 4 | 268 | 202 | 90 | 14,297 | 1,314 | 11,438 | 8" | 27' 9" | 27' 10" | 6,280 | 12,370 |
| 5 | 335 | 253 | 112 | 14,297 | 1,314 | 11,438 | 8" | 27' 9" | 27' 10" | 6,400 | 12,495 |
| 6 | 401 | 303 | 135 | 15,912 | 1,462 | 12,730 | 8" | 30' 6" | 30' 7" | 6,970 | 13,260 |
| 7 | 468 | 354 | 157 | 15,912 | 1,462 | 12,730 | 10" | 30' 6" | 30' 7" | 7,090 | 13,380 |
| 8 | 535 | 404 | 180 | 16,969 | 1,559 | 13,575 | 10" | 31' 10" | 31' 11" | 7,430 | 14,100 |
| 9 | 602 | 455 | 202 | 17,528 | 1,611 | 14,022 | 10" | 33' 3" | 33' 4" | 7,770 | 14,895 |
| 10 | 669 | 505 | 225 | 18,507 | 1,701 | 14,806 | 10" | 34' 11" | 35' | 8,110 | 15,715 |
| 11 | 736 | 556 | 247 | 18,507 | 1,701 | 14,806 | 12" | 34' 11" | 35' | 8,230 | 15,835 |
| 12 | 803 | 606 | 270 | 19,290 | 1,773 | 15,432 | 12" | 36' 3" | 36' 4" | 8,570 | 16,555 |
| 13 | 870 | 657 | 292 | 20,123 | 1,849 | 16,098 | 12" | 37' 7" | 37' 8" | 8,910 | 17,275 |
| 14 | 937 | 707 | 314 | 20,123 | 1,849 | 16,098 | 12" | 37' 7" | 37' 8" | 9,030 | 17,395 |
| 15 | 1,004 | 758 | 337 | 20,906 | 1,921 | 16,725 | 12" | 39' | 39' 1" | 9,370 | 18,115 |
| 16 | 1,070 | 808 | 359 | 21,738 | 1,998 | 17,390 | 14" | 40' 5" | 40' 6" | 9,710 | 18,835 |
| 17 | 1,137 | 859 | 382 | 21,738 | 1,998 | 17,390 | 14" | 40' 5" | 40' 6" | 9,830 | 19,855 |
| 18 | 1,204 | 909 | 404 | 22,571 | 2,074 | 18,057 | 14" | 41' 10" | 41' 11" | 10,170 | 19,675 |
| 19 | 1,271 | 960 | 427 | 23,354 | 2,146 | 18,683 | 14" | 43' 2" | 43' 3" | 10,510 | 20,395 |
| 20 | 1,338 | 1,010 | 449 | 24,138 | 2,218 | 19,310 | 14" | 44' 6" | 44' 7" | 10,850 | 21,115 |
| 21 | 1,405 | 1,061 | 472 | 24,138 | 2,218 | 19,310 | 14" | 44' 6" | 44' 7" | 10,970 | 21,235 |
| 22 | 1,472 | 1,112 | 494 | 24,970 | 2,295 | 19,976 | 16" | 45' 11" | 46' | 11,310 | 21,955 |
| 23 | 1,539 | 1,162 | 517 | 25,802 | 2,371 | 20,642 | 16" | 47' 4" | 47' 5" | 11,650 | 22,675 |
| 24 | 1,606 | 1,213 | 539 | 25,802 | 2,371 | 20,642 | 16" | 47' 4" | 47' 5" | 11,770 | 22,795 |
| 25 | 1,673 | 1,263 | 561 | 26,732 | 2,457 | 21,386 | 16" | 48' 11" | 49' | 12,110 | 23,515 |
| 26 | 1,740 | 1,314 | 584 | 27,565 | 2,533 | 22,052 | 16" | 50' 4" | 50' 5" | 12,450 | 24,235 |
| 27 | 1,806 | 1,364 | 606 | 28,397 | 2,610 | 22,718 | 16" | 51' 9" | 51' 10" | 12,790 | 24,955 |
| 28 | 1,873 | 1,415 | 629 | 28,397 | 2,610 | 22,718 | 18" | 51' 9" | 51' 10" | 12,910 | 25,075 |
| 29 | 1,940 | 1,465 | 651 | 29,180 | 2,682 | 23,344 | 18" | 53' 1" | 53' 2" | 13,250 | 25,795 |
| 30 | 2,007 | 1,516 | 674 | 29,964 | 2,754 | 23,971 | 18" | 54' 5" | 54' 6" | 13,590 | 26,515 |
| 31 | 2,074 | 1,566 | 696 | 30,796 | 2,830 | 24,637 | 18" | 55' 10" | 55' 11" | 13,930 | 27,235 |
| 32 | 2,141 | 1,617 | 719 | 30,796 | 2,830 | 24,637 | 18" | 55' 10" | 55' 11" | 14,050 | 27,355 |
| 33 | 2,208 | 1,667 | 741 | 31,628 | 2,907 | 25,302 | 18" | 57' 2" | 57' 3" | 14,390 | 28,075 |
| 34 | 2,275 | 1,718 | 764 | 32,412 | 2,979 | 25,930 | 18" | 58' 7" | 58' 8" | 14,730 | 28,795 |
| 35 | 2,342 | 1,768 | 786 | 32,412 | 2,979 | 25,930 | 18" | 58' 7" | 58' 8" | 14,850 | 28,915 |
| 36 | 2,409 | 1,819 | 809 | 33,244 | 3,055 | 26,595 | 20" | 60' | 60' 1" | 15,190 | 29,635 |
| 37 | 2,475 | 1,869 | 831 | 34,027 | 3,127 | 27,222 | 20" | 61' 4" | 61' 5" | 15,530 | 30,355 |
| 38 | 2,542 | 1,920 | 853 | 35,007 | 3,217 | 28,006 | 20" | 63' | 63' 1" | 15,870 | 31,075 |
| 39 | 2,609 | 1,970 | 876 | 35,007 | 3,217 | 28,006 | 20" | 63' | 63' 1" | 15,990 | 31,195 |
| 40 | 2,676 | 2,021 | 898 | 35,839 | 3,294 | 28,671 | 20" | 64' 5" | 64' 6" | 16,330 | 31,915 |
| 41 | 2,743 | 2,071 | 921 | 36,622 | 3,366 | 29,298 | 20" | 65' 9" | 65' 10" | 16,670 | 32,635 |
| 42 | 2,810 | 2,122 | 943 | 36,622 | 3,366 | 29,298 | 20" | 65' 9" | 65' 10" | 16,790 | 32,755 |

6 TABLE FOR 10' DIAMETER TANKS

CONTAINMENT SOLUTIONS MANUFACTURES:

Oil/Water Separators and Interceptors
Underground and Aboveground Storage Tanks
Urea DEF Storage Tanks
Compartment Tanks
ReTank® Retrofit Systems
BTU® - Biofuel Tank Upgrade
Automotive Oil and Lubricant Storage Tanks
Flowtite® Water Tanks
Chemical Storage Tanks
Fiberglass Manholes and Wetwells



5150 Jefferson Chemical Road • Conroe, Texas 77301-6834
Phone: (877) CSI-TANK or (877) 274-8265 • Fax: (936)756-7766

www.containmentsolutions.com



©2011 Containment Solutions, Inc. All rights reserved.
The Containment Solutions logo is a registered trademark of Containment Solutions, Inc. 08/2011 Pub. No. OWS2029B
For the most up-to-date information, including specifications and product warranties visit the Containment Solutions website.